

- The Trout Brook Ravines - Stormwater Retrofit Analysis

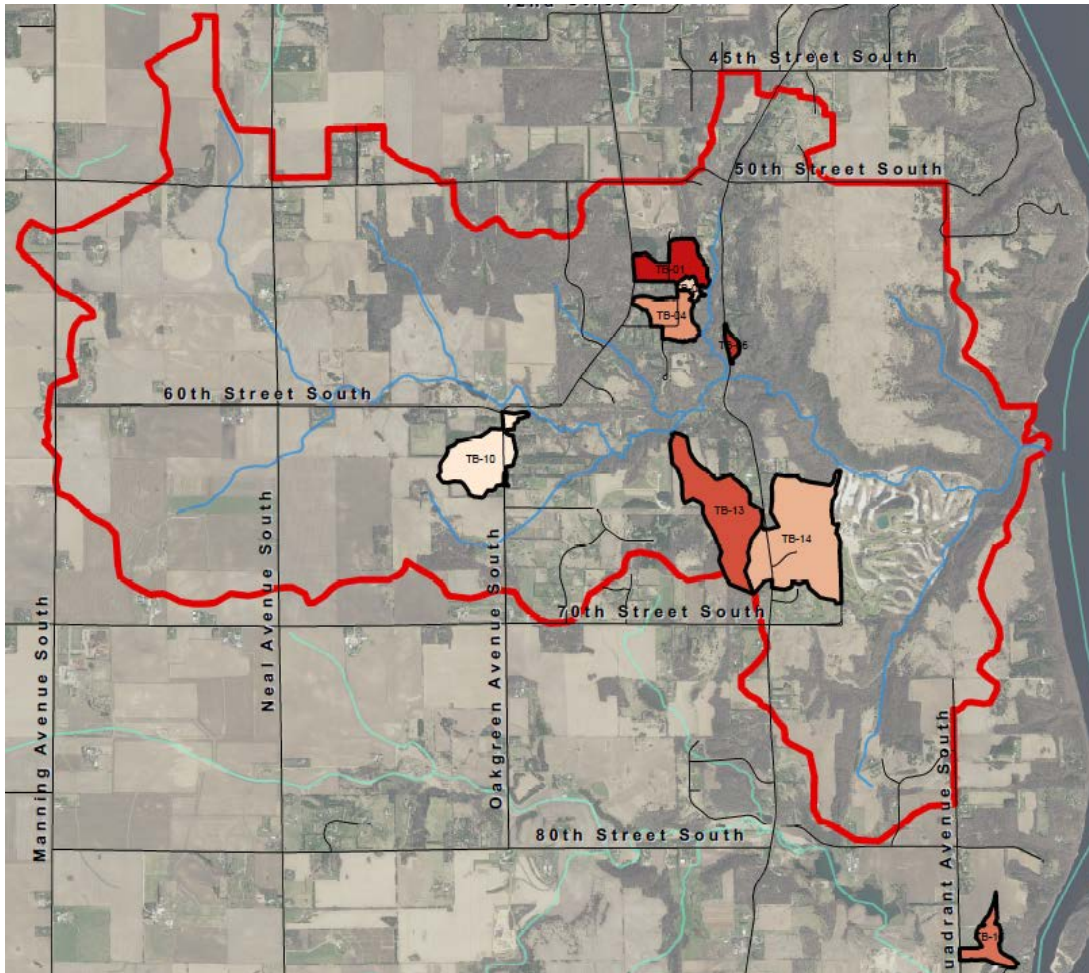

Prepared by:



For the

SOUTH WASHINGTON WATERSHED DISTRICT



July 2017

Table of Contents

Map of Prioritized Catchments found in this report.....	3
Map of Catchments ranked by Net Pollution Reduction.....	4
Executive Summary.....	5
Ranking table for all Prioritized Practices.....	6
Map of individually Ranked BMP s by location.....	7
About This Document.....	9
Methods.....	11
Catchment Profiles.....	18
TB-01: BMP 01a.....	19
TB-03: BMP 03a.....	21
TB-04: BMP 04a,b.....	23
TB-06: BMP 06a.....	25
TB-10: BMP 10a.....	27
TB-13: BMP 13a.....	29
TB-14: BMP 14a,b,c,d,e.....	31
TB-15: BMP 15a,b,c.....	36
Appendices.....	40
Appendix A: Methods.....	41
Appendix B: How to Read Catchment Profiles.....	49
Appendix C: Ranking Tables and Maps for all BMPs	55
Tables.....	57
Maps.....	58-81

Catchments Studied – Catchments studied in this report. All ravines that showed potential erosion from the Stream Power Index were field verified for retrofit/repair potential.

Rank by Total Phosphorus Reduction

-  Catchments Modelled for Retrofit
-  High SPI Rank, but Field Verified as Stable – Not Modelled for Retrofit
-  Trout Brook Catchment Boundary

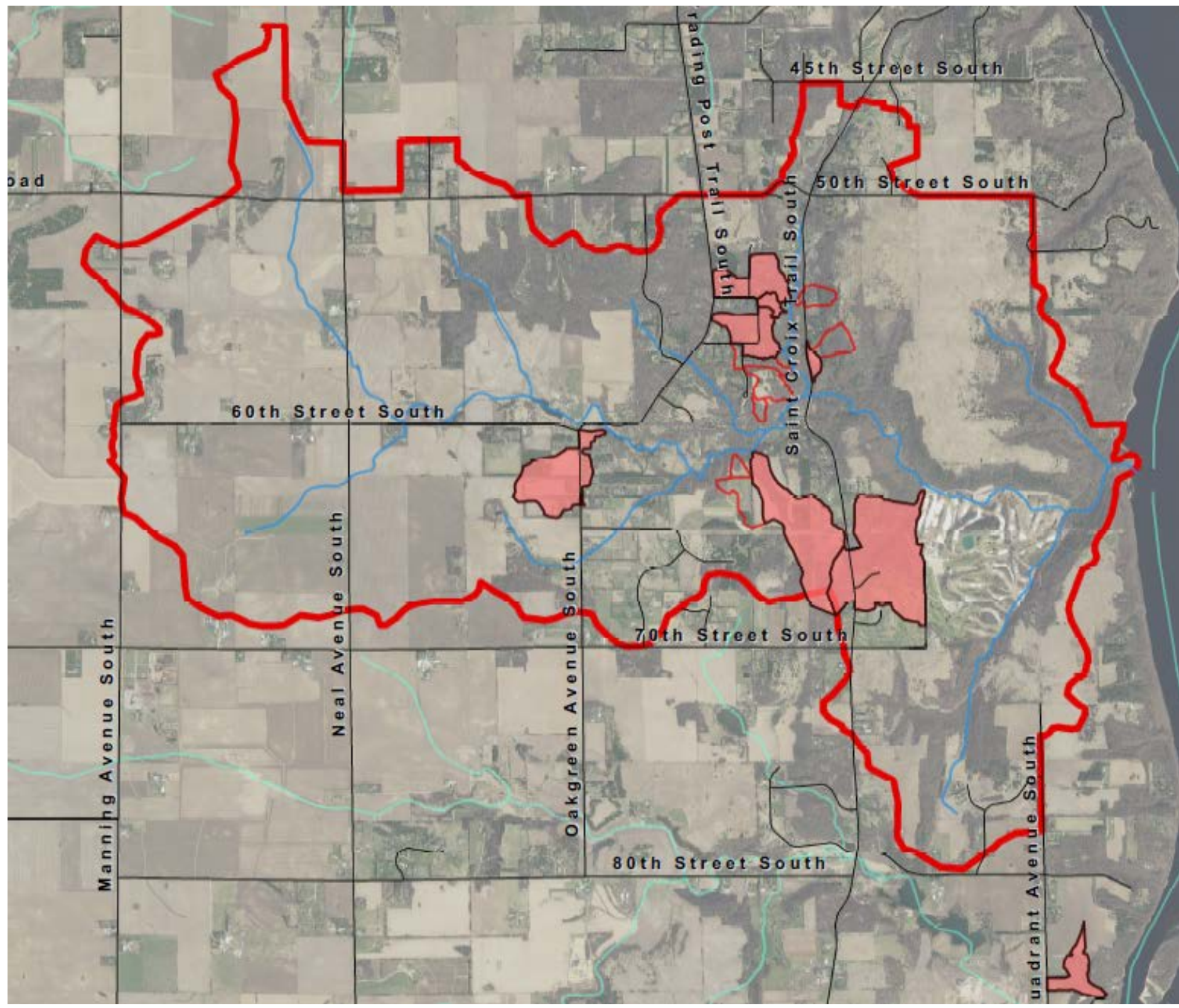

Prioritized Rankings by Catchment - rank of stormwater catchments studied to in this report
(Ranked by TP load reduction if all practices were installed per ravine catchment)

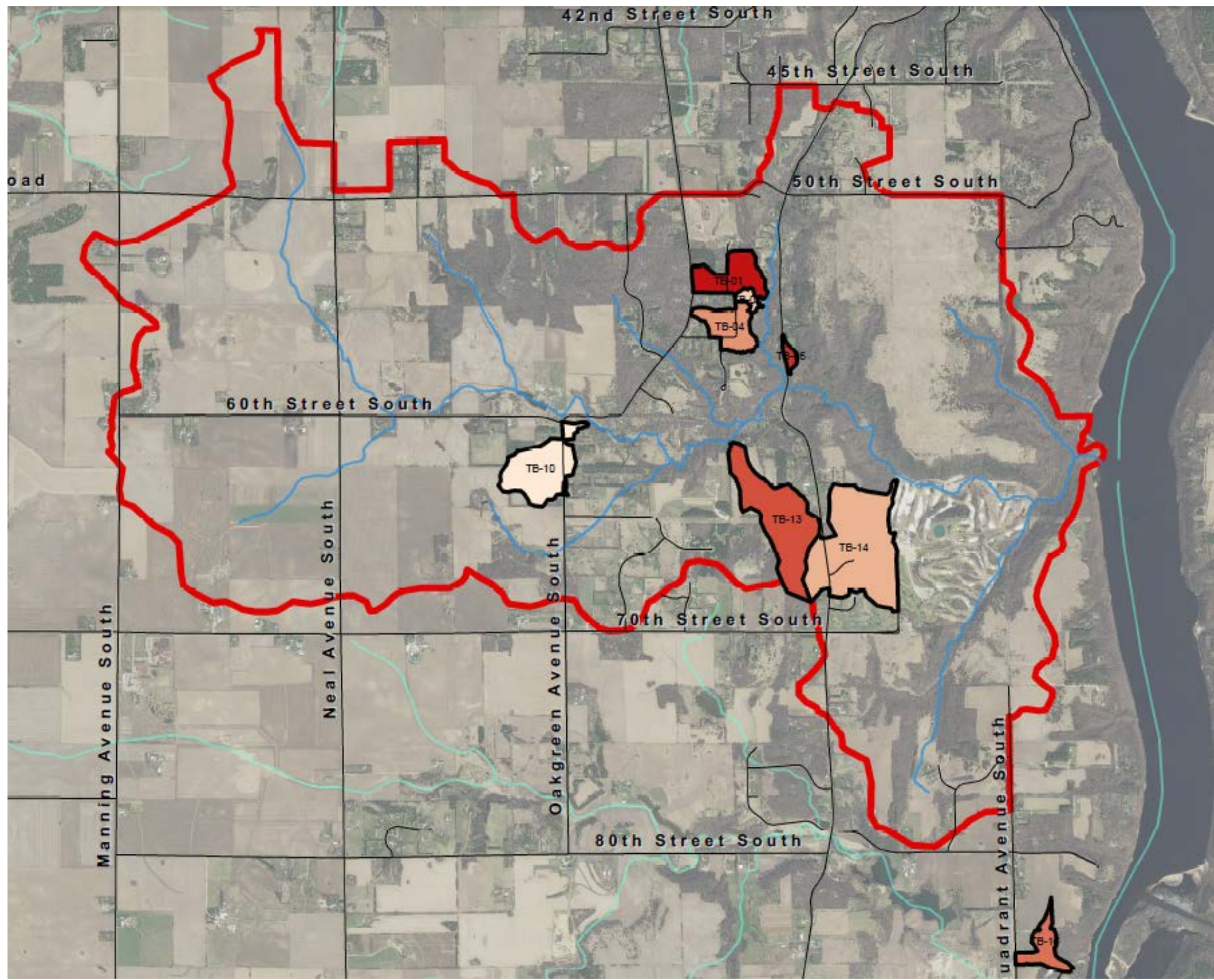
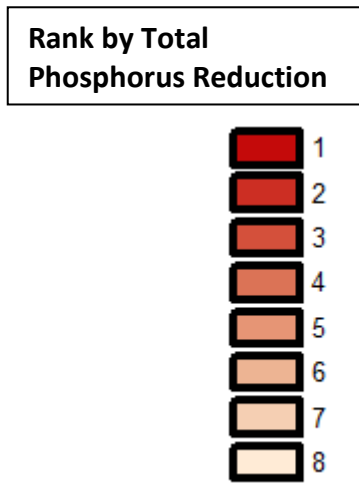

Executive Summary

This analysis provides a prioritized list (ranked by cost effectiveness) of stormwater retrofit recommendations to stabilize ravines that drain directly to Trout Brook; a significant tributary to the St. Croix River. This area is entirely located within the South Washington Watershed District (SWWD) boundary, and spans the municipalities of Afton Township and Denmark Township.

For this analysis, we used the Stream Power Index to identify ravines which posed the greatest erosion potential. After field verifying each potential ravine, we narrowed the analysis list from 15 to 7 potential ravines to model. One ravine was found outside the Trout Brook catchment, but was found to be large enough to warrant including in this analysis.

The ravines were all modelled using a combination of methods. The BWSR Pollution Reduction Estimator Spreadsheets were used to model gully erosion and soil loss volumes. These values were then added to a land cover model appropriate to the catchment land use. RUSLE and RUSLE2 were used for agricultural lands and sediment delivery for steep, wooded slopes. WinSLAMM was used for any catchment that had roads and impervious surfaces (typically suburban in nature).

The proposed stormwater management practices within each catchment were analyzed for annual pollutant loading - Total Phosphorus (TP), Total Suspended Solids (TSS) and Water Quality Volume (WQV) specifically. All known existing BMPs and their load reductions were accounted for in the modeling process. Ravines with a significant Stream Power Index signature were investigated via field reconnaissance. Proposed BMP options were then compared for each sub-catchment, given their specific site constraints and characteristics. Each final stormwater practice was selected and ranked by weighing cost, pollution reduction benefits, ease of installation and maintenance, and ability to serve multiple functions. A Ranking Table can be found on the following page and in the Appendix.

Much of the watershed sits at the interface between the Jordan Sandstone (upper strata) and the St Lawrence Formation (lower strata along creek). Atop the St Lawrence Formation is the Lodi member, a siltstone formation, which is often the layer in which groundwater will travel and expose itself halfway down many of the ravines. This persistent groundwater interaction has caused bank failure in many ravines and has forced us to look at structural embankments as a BMP (such as gabion walls).

The cost-benefit value for annual TP reduction over 30 years ranges from \$64 to \$955 per lb of TP, with an average value of \$319. Even the lowest ranking practices modelled would rank very high in a traditional SWA; where ravine repairs are not typically considered. But, when comparing ravine repairs to each other, there are obviously better ravine projects than others. The best value projects in this report would therefore be the first 8 of 12. Over a 30 year These 8 practices rank less than \$319 average cost per lb. of TP annually.

Stormwater Retrofit Ranking by BMP Cost Effectiveness

The following table summarizes the assessment results, ascending in rank by \$Cost per Lb of TP removed over 30 years. Reported treatment levels are dependent upon optimal siting and sizing. The recommended treatment levels/amounts summarized here are based on a subjective assessment of what can realistically be expected to be installed considering expected public participation and site constraints. See Map on page 7, individual Catchment Profiles, or Appendix C for BMP locations. See Methods Section for how rankings were determined.

Project Rank	Catchment ID (TB-##)	Retrofit Type (refer to catchment profile pages for additional detail)	Locations Identified	TP Reduction (lb/yr)	TSS Reduction (ton/yr)	Volume Reduction (ac-ft/yr)	Total Project Cost	Estimated Annual O & M (2017 Dollars)	Estimated cost/ lb-TP/year (30-year)	Estimated cost/ ton-TSS/year (30-year)
1	TB-15	15a+b: Upper Ravine Stabilization	10	26.06	29.2	0.6	\$46,340	\$133	\$64.39	\$57.56
2	TB-01	1a: Head Cut Repairs and Rate Control	1	17.7	15	0.0	\$41,058	\$100	\$82.97	\$95.36
3	TB-06	6a: New Curb and Gabion Basin	1	20.57	22.35	0.72	\$56,481	\$200	\$101.25	\$93.19
4	TB-13	13a: Bank Stabilization and Headcut Repair	4	12.63	14.8	0.0	\$37,774	\$67	\$104.97	\$89.40
5	TB-14	14e: Gabion Sediment Basin	1	33.51	33.5	0.0	\$88,924	\$833	\$113.31	\$113.31
6	TB-14	14c + d: Thalweg and Pipe Corrections	10	7.01	7.0	0.0	\$32,250	\$75	\$164.05	\$164.05
7	TB-04	4a: Head Cut Repairs and Rate Control	3	8.37	5.1	0.8	\$52,381	\$333	\$248.43	\$409.32
8	TB-15	15c: Lower Ravine Thalweg Corrections	10	5.60	6.6	0.0	\$45,584	\$133	\$295.08	\$250.37
9	TB-14	14b: Pond IESF Retrofit	1	1.60	0.59	0.17	\$18,271	\$200	\$505.65	\$1,371.24
10	TB-14	14a: Pond IESF Retrofit	1	1.25	0.48	0.07	\$15,566	\$167	\$548.43	\$1,422.27
11	TB-03	3a: Head Cut Repairs and Rate Control	1	0.92	0.9	0.0	\$14,751	\$100	\$643.15	\$643.15
12	TB-10	10a: Headcut Repair	1	0.53	0.6	0.0	\$12,944	\$75	\$955.60	\$816.88

Ranking map of locations of standalone BMP projects referred to in this report. This map only includes BMP locations (ranking table on preceding page). The 'Catchment Profiles' section provides additional detail on these projects. See Appendix for additional ranking of all identified practices.

- BMP_Rank**
- 1 - 5
 - 6 - 8
 - 9 - 11
 - 12

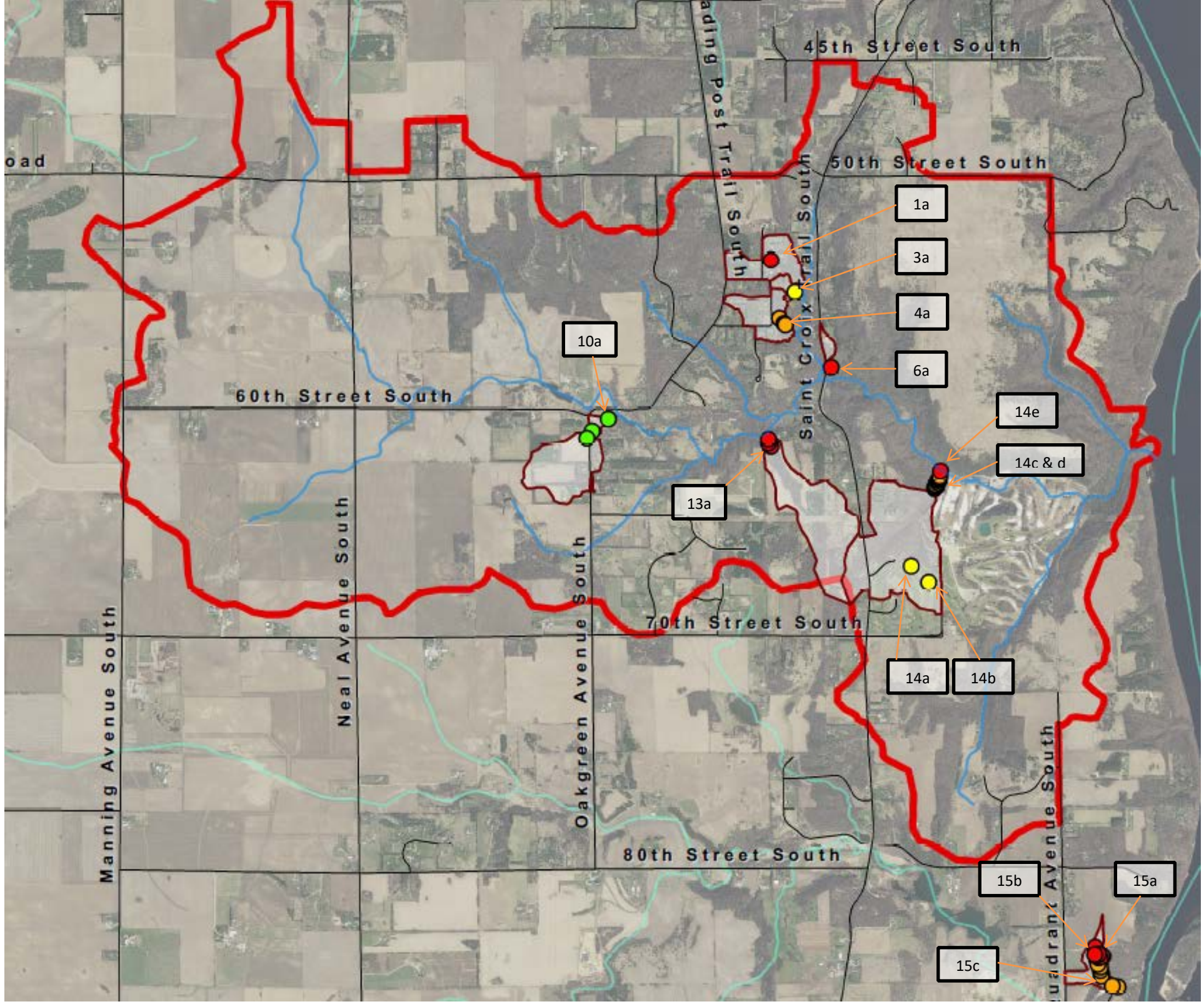

Intentionally Blank

About this Document

This Subwatershed Stormwater Retrofit Analysis is a watershed management tool to help prioritize stormwater retrofit projects by performance and cost effectiveness. This process helps maximize the value of each dollar spent.

Document Organization

This document is organized into three major sections, plus references and appendices. Each section is briefly described below.

Methods

The methods section outlines general procedures used when analyzing the subwatershed. It provides an overview of processes involved in retrofit scoping, desktop analysis, retrofit reconnaissance investigation, cost/treatment analysis and project ranking. See Appendix A for a detailed description of the methods for both the overall analysis as well as for how other practices were factored into the modelling and reporting.

Catchment Profiles

The Trout Brook Catchment boundary was from existing catchment delineation data that was provided by the South Washington Watershed District. Subcatchments were delineated based on the each ravine outlet to Trout Brook. The numbering system for identifying catchments is only for use in this report and subcatchment boundaries are not considered official. There are seven total catchments analyzed in this report. For each catchment, the following information is detailed:

Catchment Description

Within each catchment profile is a table that summarizes basic catchment information including acres, land cover, parcels, and estimated annual pollutant and volume loads. A brief description of the land cover, stormwater infrastructure, and any other important general information is also described. Existing stormwater practices are noted, and their estimated effectiveness presented. Appendix B outlines how to read a typical Catchment Profile.

BMP Retrofit Recommendations

The recommendation section describes the conceptual retrofit(s) that were identified. It includes tables outlining the estimated pollutant removals by all practices proposed, as well as costs and overall cost-benefit ranking. Following this Retrofit Recommendations summary page, each practice has its own page which includes a map, individual cost-benefit analysis, and site specific comments on the individual proposed retrofit.

Retrofit Rankings (included in Appendix C)

This section ranks stormwater retrofit projects across all catchments to create a prioritized project list. The list is sorted by cost-per-pound of total phosphorus removed for each project over 30 years. The final cost-per-pound treatment value includes design, installation, and maintenance costs (in 2017 dollars). Cost estimates vary in precision due to exposure to real-world bids for specific practices, and will also vary when unknown site parameters are addressed during the design phase.

There are many possible ways to prioritize projects, and the list provided is merely a starting point. Other considerations for prioritizing installation may include:

- Non-target pollutant reductions
- Timing projects to occur with other CIPs
- Project visibility
- Availability of funding
- Total project costs

- Educational value
- Additional ecological and habitat connectivity value

References

This section identifies various sources of information synthesized to produce the assessment protocol used in this analysis.

Appendix

This section provides supplemental information and/or data used in various portions of the assessment protocol. It also includes larger maps of each proposed BMP.

Methods (specific to this report only)

BioFiltration, BioInfiltration, and WASCObS

Summary

Biofiltration and BioInfiltration are the primary BMPs chosen for residential areas where rate control or pollution reduction is needed above a ravine. WASCObS and Grade Stabilizations are very similar in function, but are reserved for rural areas, have larger footprints, and can handle a greater volume of water.

BioInfiltration

BioInfiltration is a basin that infiltrates into the native soil fast enough to allow for a fully drained basin within 48 hours. There are no underdrains in a BioInfiltration Basin. All basins of either type in the analysis do not have pretreatment devices to limit gross solid accumulation and rely on additional tall vegetation upstream to capture sediment prior to entering the basin.

BioInfiltration Basin

Infiltration Zone with Vegetated Pretreatment

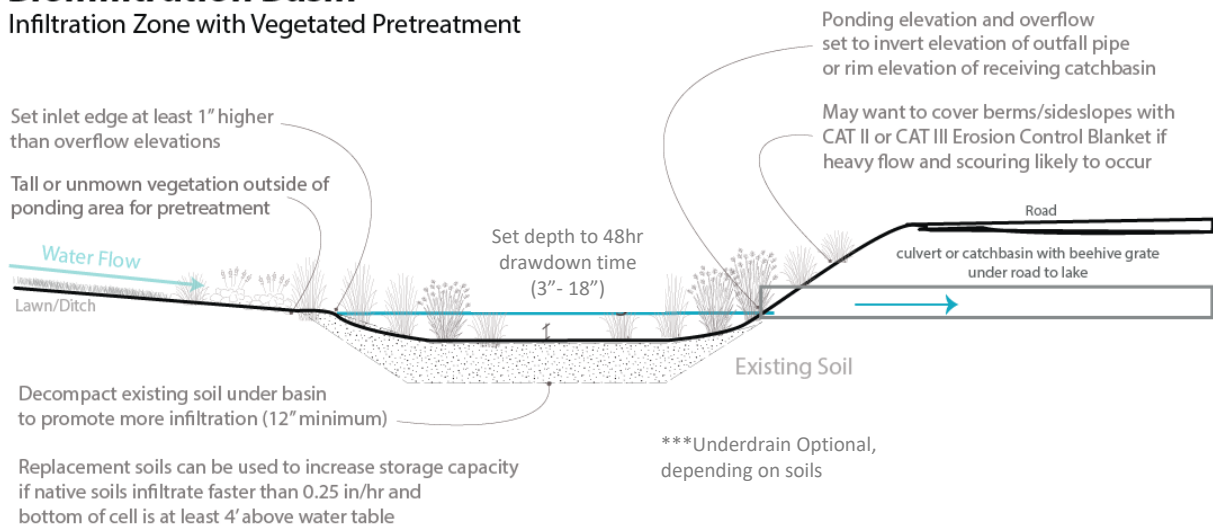

Concept Plan

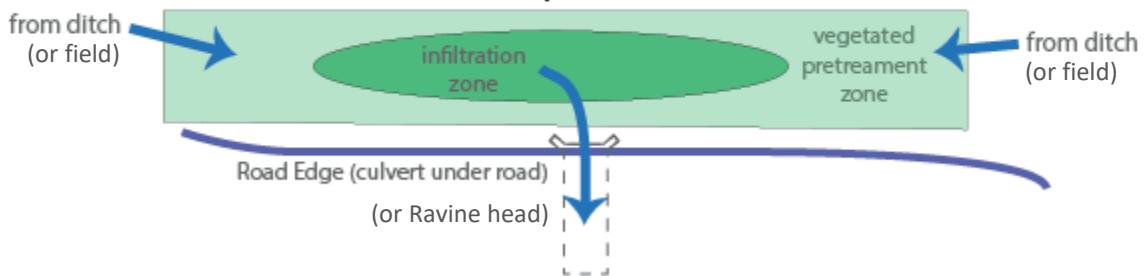

Methods *(specific to this report only)*

BioFiltration, BioInfiltration, and WASCOBs

WASCOBs and Grade Stabilizations

Water and Sediment Control Basins (WASCOBs) - A series of small embankments across concentrated flow paths on cropland that store then slowly release runoff through an underground outlet. As sediment laden runoff enters the basin, it is stored and sediment is settled out. The intakes that meter the water out are typically a plastic perforated stand pipe about 4 feet high. The embankments themselves can be designed to be farmed (MN NRCS).

Grade Stabilization Structures – These types of structures are designed to convey runoff across a steep drop in a non-erosive manner. Typical applications include dropping runoff flows from field level down into a ditch with a pipe or an open rock chute. Larger applications such as controlling the advancement of a large ravine or gully up into a field usually involve long lengths of pipe to convey runoff flows down to a stable outlet (MN NRCS). Both practices are used (sometimes in tandem) for many of the sites in this study.

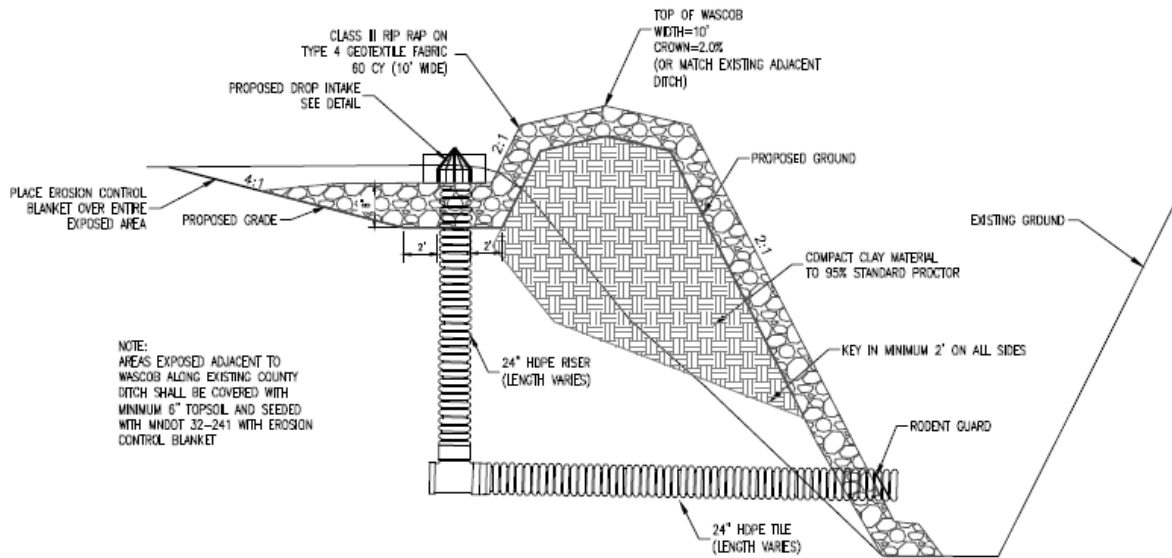

WASCOB SIDE INLET DETAIL

N.T.S.

Infiltration Basins and WASCOBs

Best used above ravine head for volume and rate control.

Best in multiple locations to break drainage area into smaller, more manageable components

Added benefit of pollutant capture from contributing drainage area (and not just for erosion control in ravine itself)

Modelling Pollutant Load Reductions for Infiltration Basins and WASCOBs:

WinSLAMM was used to model infiltration basins in areas that had impervious surfaces and a suburban landuse. Water Quality Volume (WQV), Total Suspended Solids (TSS), and Total Phosphorus (TP) were modelled. RUSLE2 was used to account for landscapes that were agricultural or undeveloped. Only sediment load is modelled in RUSLE2. In order to get a TP reduction for WASCOBs, the RUSLE2 sediment yield was entered into the BWSR Pollution Reduction Estimator Spreadsheet to obtain a pre and post-installation TP value. These values are then added to any TP and TSS reductions calculated for direct erosional losses in the ravine. It was assumed that a properly sized basin would account for a 50% reduction in TSS for the local area being repaired. Each ravine is unique as to the extent of this 'repair zone'.

In-Channel Erosion Control and Sediment Capture Practices

Summary

Larger ravines in this study call for practices that are often used in ditch and stream management. These are all practices that are inserted into the flow path and are intended to either limit head-cutting and down-cutting, or are intended to protect the side banks from eroding further. Simple armoring of headcuts with riprap can work, but often need to be combined with some form of flow redirection. These practices redirect the thalweg (the strongest portion of the flowpath) away from the eroded banks of the ravine. Check dams, Cross vanes, and other similar stream management practices are recommended in tandem with larger restoration efforts as part of a ravine stabilization project. Below are typical sections of practices recommended for grade stabilization and thalweg corrections.

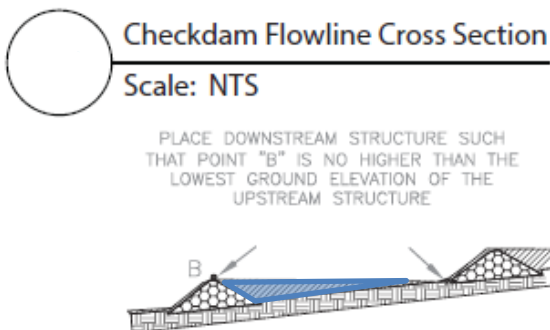
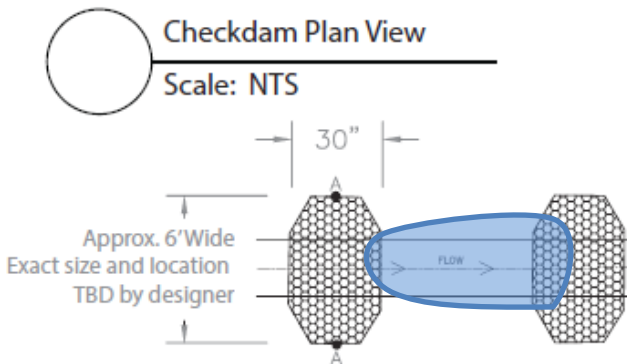
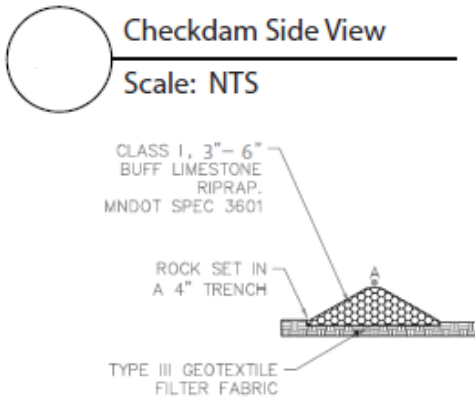

Check Dams

Used for grade stabilization, flow control, and rate control.

Can be used in a shallow sloped ditches to impound water temporarily, allowing sediment to drop out.

Only recommended for practices that are upstream of the ravines, where longer duration ponding can occur.

Most practices in this report will rely on hard armoring of headcuts rather than checkdams.

Modelling Pollutant Load Reductions for Checkdams:

Checkdams used for ponding and settling are modelled in WinSLAMM and are treated like an infiltration basin with minimal ponding. The underlying soils are classified as HSG C (unless replacement soils and underdrains are introduced). Pollution reductions are only significant if many are installed in succession and the slopes are shallow.

Erosion losses in the channel are typically only accounted for in modelling of Headcut Repairs, where direct losses of the eroded soil are accounted for.

Methods (specific to this report only)

In-Channel Erosion Control and Sediment Capture Practices

Hard Armoring and Headcut Repair

Hard armoring is the technical placement of various sized rocks along a flow path or channel slope, reducing the flow energy of the stream and stabilizing the headcut.

Used as a spillway or as a headcut stabilization method.

Modelling Pollutant Load Reductions for Headcut Repairs:

Only the direct losses from headcut being repaired are counted (the volume of the eroded zone lost over a field-identified duration of time). A conservative 50% credit for TSS and TP reductions is given to all headcut repairs. It is anticipated that side-bank losses may still occur in the largest of rain events.

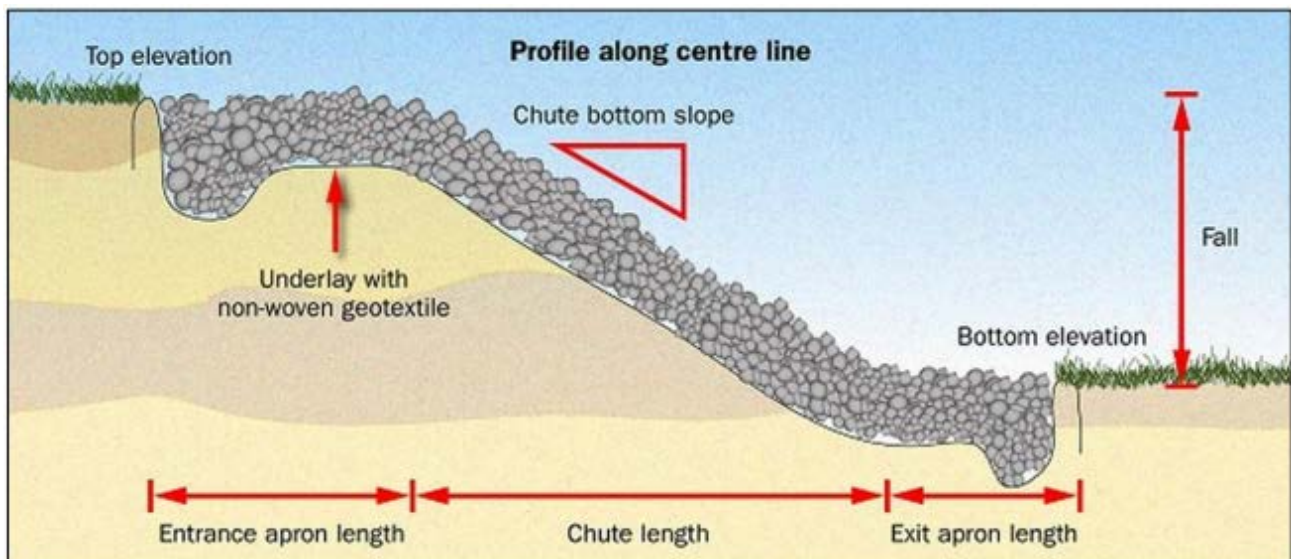

Rock Chute Spillway: Headcut Restoration and Diversion Spillways
(Ontario Ministry of Agriculture and Food)

Methods (specific to this report only)

In-Channel Erosion Control and Sediment Capture Practices

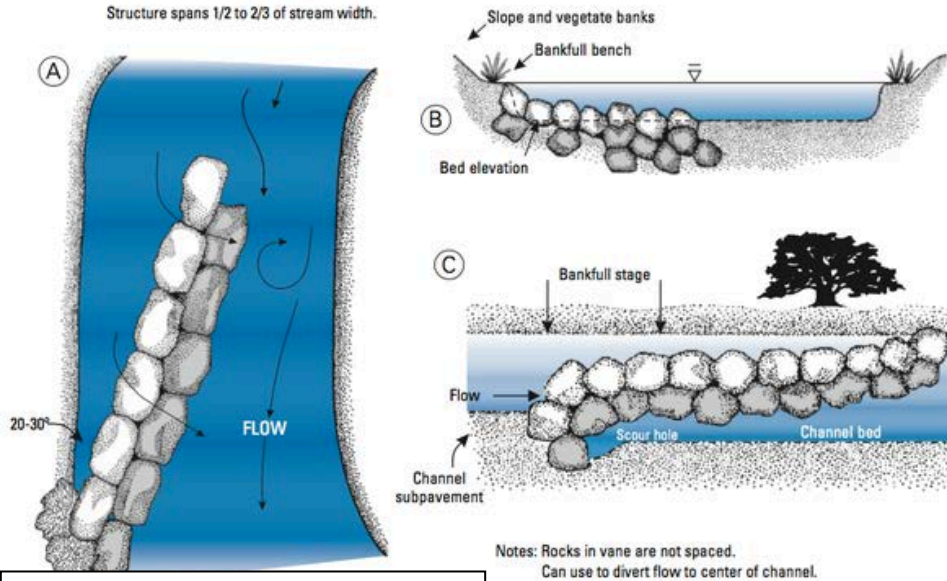

Rock Vane: Thalweg Correction
(NC State Extension)

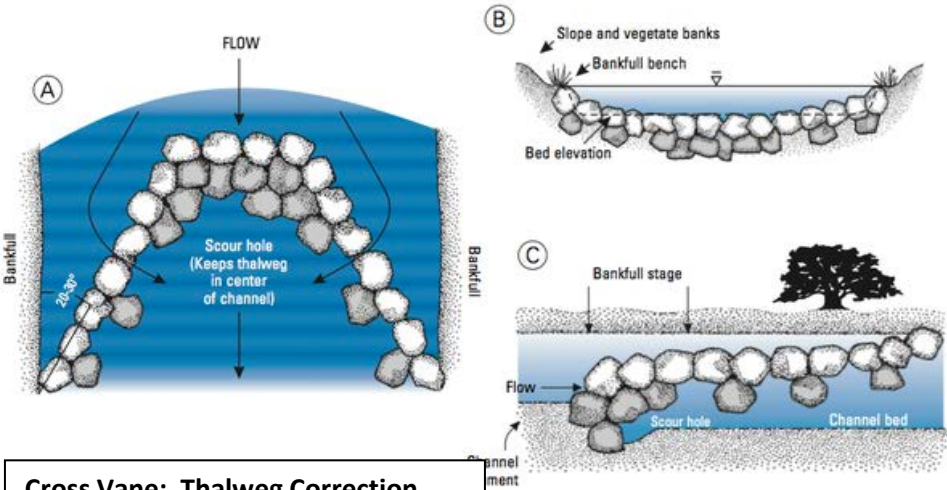

Cross Vane: Thalweg Correction and Grade Stabilization
(NC State Extension)

Rock Vanes and Cross Vanes

Typical Thalweg Control practices used in stream restoration.

For this analysis, recommended in large, steep, heavily eroding ravines that are meandering and cutting into banks. Flows are so heavy and frequent in these ravines that the solutions lie more in flow management rather than basic armoring.

Redirects flow away from the undercutting banks.

Promotes deposition in areas upstream and downstream (depending on practice and placement).

Reduces energy of flow if used frequently enough along flow path.

Used in conjunction with toe and bank stabilization practices in order to be completely effective.

Modelling Pollutant Load Reductions for Thalweg Control:

Only the direct erosion from the flow path undercutting the bank being restored is credited. A conservative 50% credit for TSS and TP reductions is given to all Thalweg Corrections. It is anticipated that side-bank losses may still occur in the largest of rain events.

Methods (specific to this report only)

In-Channel Erosion Control and Sediment Capture Practices

Gabion Check Dams, Toe Reinforcement, and Sediment Basins

Gabion Walls are being proposed for several practices. They are strong enough to withstand considerable flow, but also permeable enough to allow several CFS of water to pass through. They can be used as Toe Reinforcement for bank erosion where groundwater seeps are present. They can be used as a grade stabilization and headcut practice. They are also being proposed as the weir wall for large sediment collection basins.

Modelling Pollutant Load Reductions for Headcut Repairs:

All gabion practices for sediment basins are credited at 50% TP and TSS reduction due to their permeability. Gabions used for toe reinforcement get 100% credit for the bank area being repaired. Gabions as headcut repair/check dams are given 50% credit for the direct erosion that is being stabilized at the practice location.

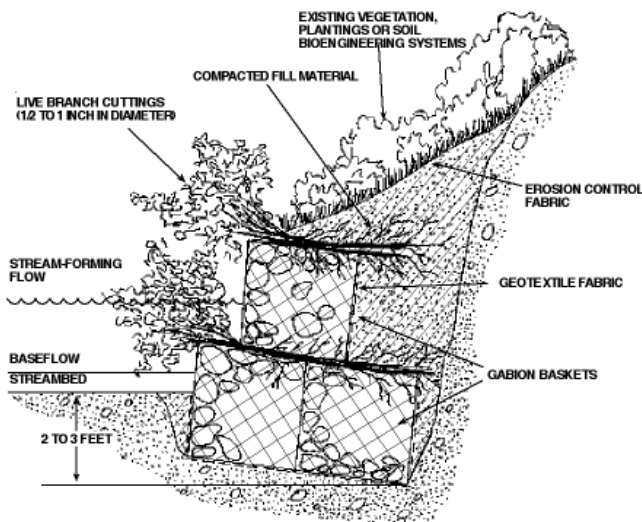
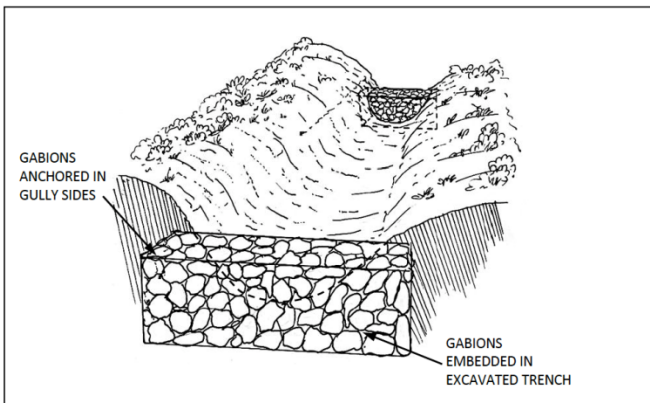

Methods (specific to this report only)

Iron Enhanced Sand Filter (IESF)

Iron Enhanced Sand Filter Pond Bench Retrofit

Iron enhanced sand filters help to remove dissolved phosphorus that typical bioinfiltration practices cannot. Efficiencies in removal for IESF range from 30% to 90% reduction in dissolved phosphorus. The study chose a 50% removal rate of dissolved phosphorus to account for inefficiencies in removal rates as the practice ages. Below is a typical section for an IESF pond bench retrofit. There will likely be a deviation from this design to fit site specific constraints of the IESF proposed in this report.

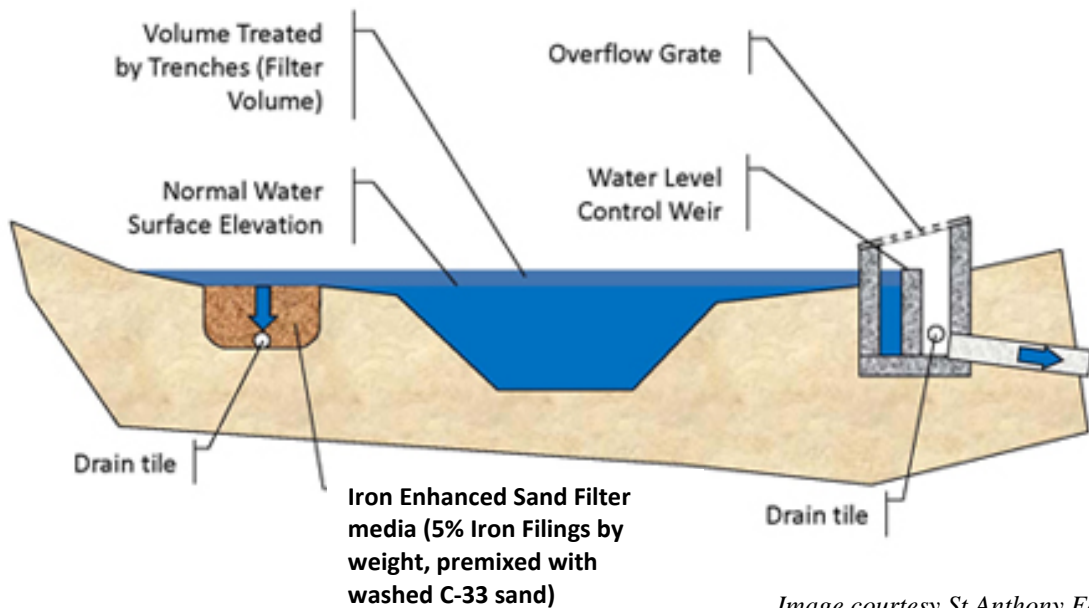

Image courtesy St Anthony Falls Laboratory, MN (2009)

Catchment Profiles and BMP Rankings

Catchment TB-01



CATCHMENT DESCRIPTION

Catchment TB-01 is medium sized ravine and is a mix of low density residential and agriculture. The catchment has been historically agriculture, but has recently built homes. Near the top of the ravine, aerial photos show that this area has always been avoided for farming or tilling. Recently, groundwater issues have increased at the top of the ravine, resulting in many large slumps and slides in the last few years. Increased saturation and groundwater appear to be the driving force behind the losses. The presence of groundwater or saturated soils may explain why this area has not been farmed or tilled in the past.

TB-01: BMP 1a – Headcut Repairs and Rate Control

Drainage Area – 28.52 acres
Location – Litton property, TB-01
Property Ownership – Private



Description – This practice is in the design phase as of the writing of this report. Pollutant loads were modelled by the Washington Conservation District using a combination of HydroCAD and the BWSR Pollution Reduction Estimator Spreadsheets.

Gabions will be used as toe stabilization where the seeps are most present. And second gabion 2-tier check dam will be used as part grade stabilization and part sediment trap.

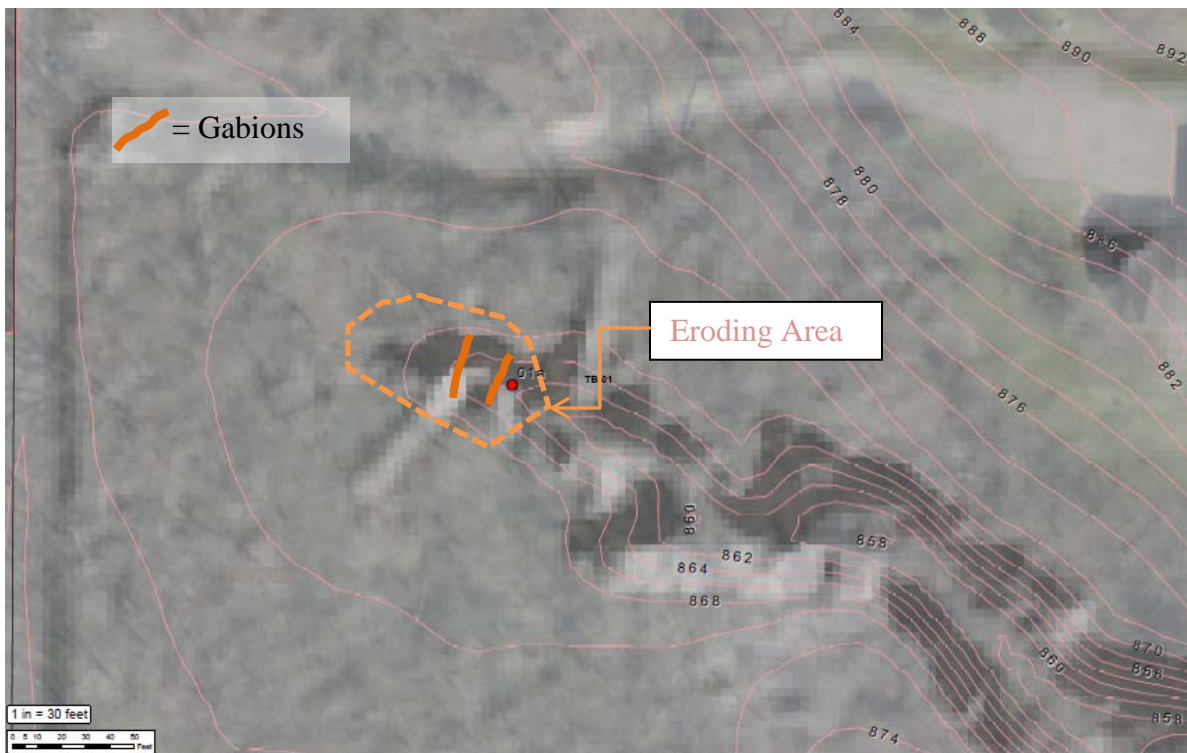

Retrofit Options		
Catchment TB-01		
Cost/Removal Analysis		1a: Head Cut Repairs and Rate Control Litton Ravine
Treatment	TP (lb/yr)	17.70
	TSS (ton/yr)	15.4
	Volume (acre-feet/yr)	0.0
	Number of BMP's	1
Cost	Materials/Labor/Design	\$39,558.00
	Promotion & Admin Costs	\$1,500
	Probable Project Cost	\$41,058
	Annual O&M	\$100
	30-yr Cost/lb-TP/yr	\$83
	30-yr Cost/ton-TSS/yr	\$95

Catchment TB-03



CATCHMENT DESCRIPTION

Catchment TB-03 is small catchment with a small steep ravine bordered by two homes. This ravine is showing higher losses than expected, given how small the catchment is. This site is directly adjacent to the TB-01, so it is expected that the losses are from increased groundwater issues, similar to the Litton Ravine.

TB-03: BMP 3a – Headcut Repairs and Rate Control

Drainage Area – 4.46 acres
Location – Babinski property, TB-03
Property Ownership – Private

Rank
11 of 12

Description – This practice is similar to TB-01 in that it aims to limit slumping caused by saturation at the toes from groundwater exposures.

Gabions will be used as toe stabilization where the seeps are most present. Since Gabions are the main feature, the cost to benefit is fairly low. If a simpler rock armoring and vegetative toe stabilization practice can be used, the install cost would lower and the practice would rank higher.



Retrofit Options		
Catchment TB-03		
Cost/Removal Analysis		3a: Head Cut Repairs and Rate Control Babinski Ravine
Treatment	TP (lb/yr)	0.92
	TSS (ton/yr)	0.9
	Volume (acre-feet/yr)	0.0
	Number of BMP's	1
Cost	Materials/Labor/Design	\$13,251.00
	Promotion & Admin Costs	\$1,500
	Probable Project Cost	\$14,751
	Annual O&M	\$100
	30-yr Cost/lb-TP/yr	\$643
	30-yr Cost/ton-TSS/yr	\$643

Catchment TB-04



CATCHMENT DESCRIPTION

Catchment TB-04 is larger catchment with a long ravine flowing through a city parcel. This has multiple sites where bare soils and head cuts exist. There is also extensive bank failure near Osgood Ave, on the south fork of the ravine. Landowners have tried to fill the cut, but it keeps receding. Groundwater seeps are present in multiple places, and near the same elevation as TB-01 and TB-03.

TB-04: BMP 4a – Headcut Repairs and Rate Control

Drainage Area – 25.43 acres

Location – Intersection of Osgood Ave S and 57th St S, TB-04

Property Ownership – Public, City of Afton

**Rank
7 of 12**

Description – Install Gabions to control rate of flow and armoring of headcuts in upper ravine.

Install 1 filtration basin above Osgood Ave at the head of the ravine. Underdrain optional, depending on borings. Soil maps show HSG C and D (but ravine is HSG A). May be able to tap into sandy soils about 8’ below grade.

Install 1 course of gabions below the “Y” in the upper ravine to impound 2,500 sq ft of water (2’ depth). Gabions will also be inserted at a headcut and 50’ downstream of that headcut; where the seeps are present. Seeps are at a similar geologic position as the Litton Ravine (TB-01).

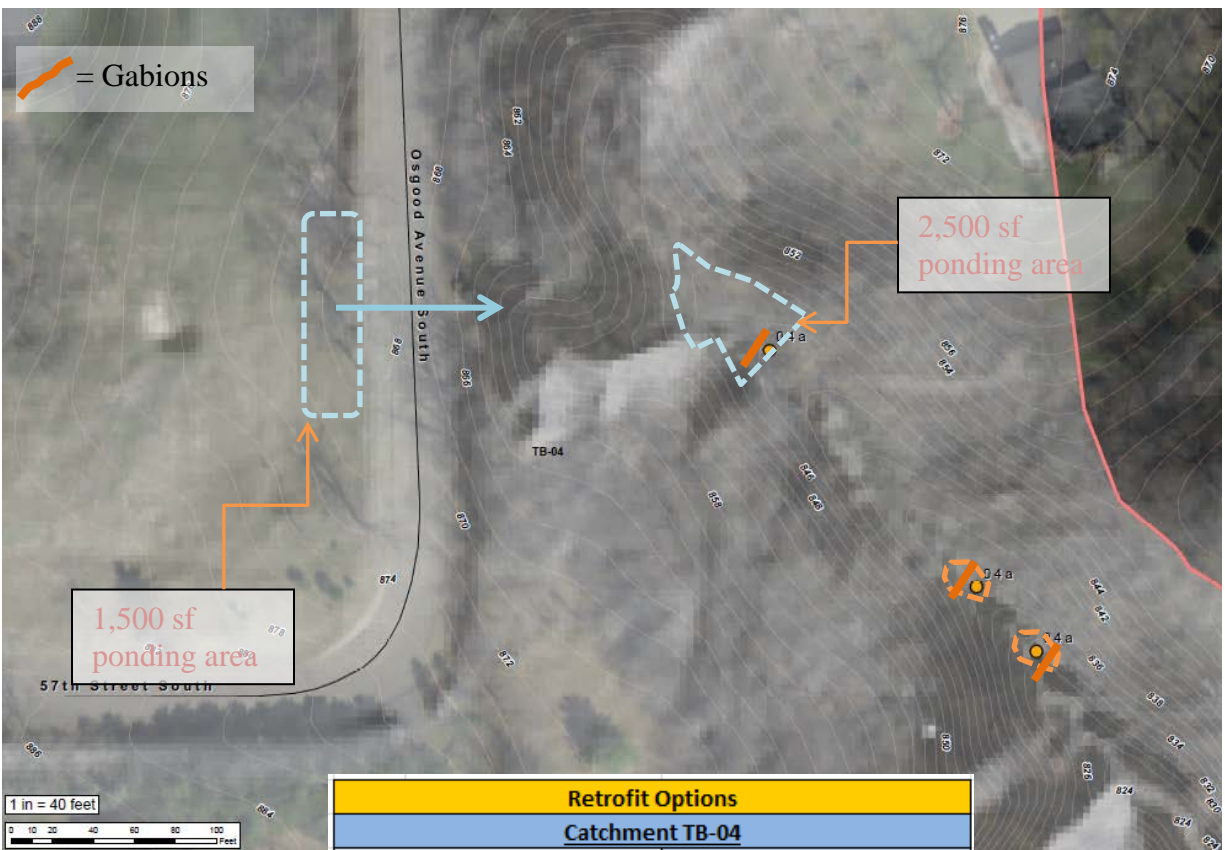

Retrofit Options		
Catchment TB-04		
Cost/Removal Analysis		4a: Head Cut Repairs and Rate Control Osgood Park Ravine
Treatment	TP (lb/yr)	8.37
	TSS (ton/yr)	5.1
	Volume (acre-feet/yr)	0.8
	Number of BMP's	3
Cost	Materials/Labor/Design	\$50,131.12
	Promotion & Admin Costs	\$2,250
	Probable Project Cost	\$52,381
	Annual O&M	\$333
	30-yr Cost/lb-TP/yr	\$248
	30-yr Cost/ton-TSS/yr	\$409

Catchment TB-06

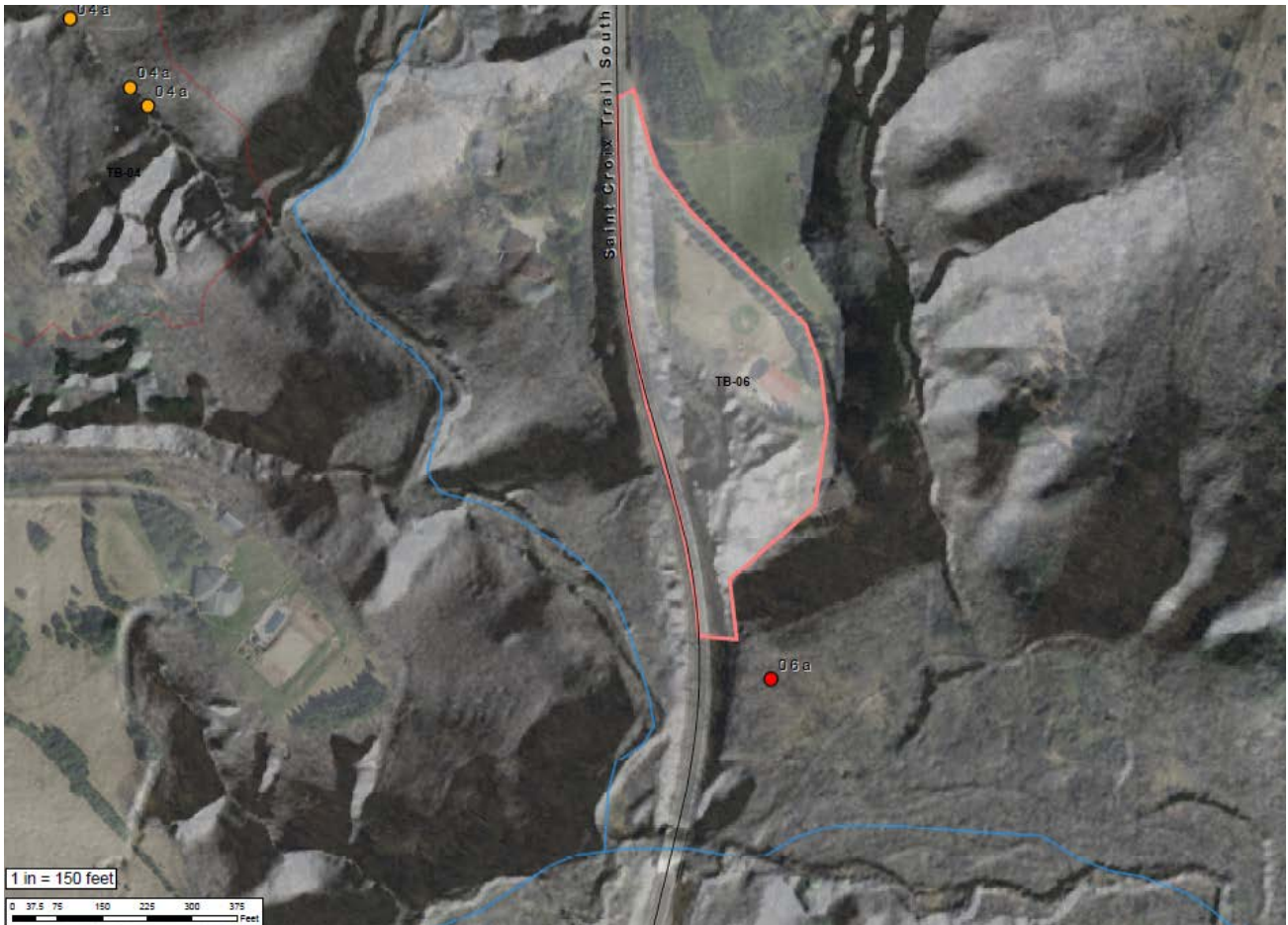

CATCHMENT DESCRIPTION

Catchment TB-06 is along Stagecoach Trail. It's a small, steep catchment that drains to a large flat above Trout Brook. There are multiple head cuts that exist along the road that flow into one large channel as it progresses south towards the creek. Much of the sand that deposits in the flat above the creek eventually gets washed into the creek, even though it appears there is ample room for settling to occur. The road will be at risk of undercutting in the future if something is not done about the erosion.

It appears many attempts at repairing this erosion have taken place, all of which just move the erosion further south along the roadway. The only true fix would be to install a full concrete curb, and collect it at the bottom of the hill, diverting it to a new basin downhill where the water can deposit sediment safely before entering the stream.

TB-06: BMP 6a – New Curb and Gabion Basin



Drainage Area – 3.70 acres

Location – Intersection of Trout Brook trailhead along Stagecoach, TB-06

Property Ownership – Public/Private, City of Afton/Washington County/ Afton State Park

Description – Install 500LF of new concrete curb to divert flow to downstream gabion basin.

By installing 500LF of concrete curb, the vast majority of erosion can be stopped in this ravine. This new curb will direct flow to a single structure near the 796' contour in the roadway, and discharge into a shallow basin that is constructed behind a gabion wall 1 course high (2' of vertical storage). There will be roughly 150LF of gabion wall, which has about 3000sf of storage area. There is enough storage volume behind this wall to require cleanout every 25 years. A berm with an armored weir would also be possible here, but infiltration of underlying soils would be a critical consideration since an earthen berm does not weep like a gabion wall would. If installing in Afton State Park is not viable, there is the possibility to store all of this volume on the property north of the park, in the ravine itself where the flow path starts to widen. All overflows would still flow into the park property as it currently exists.

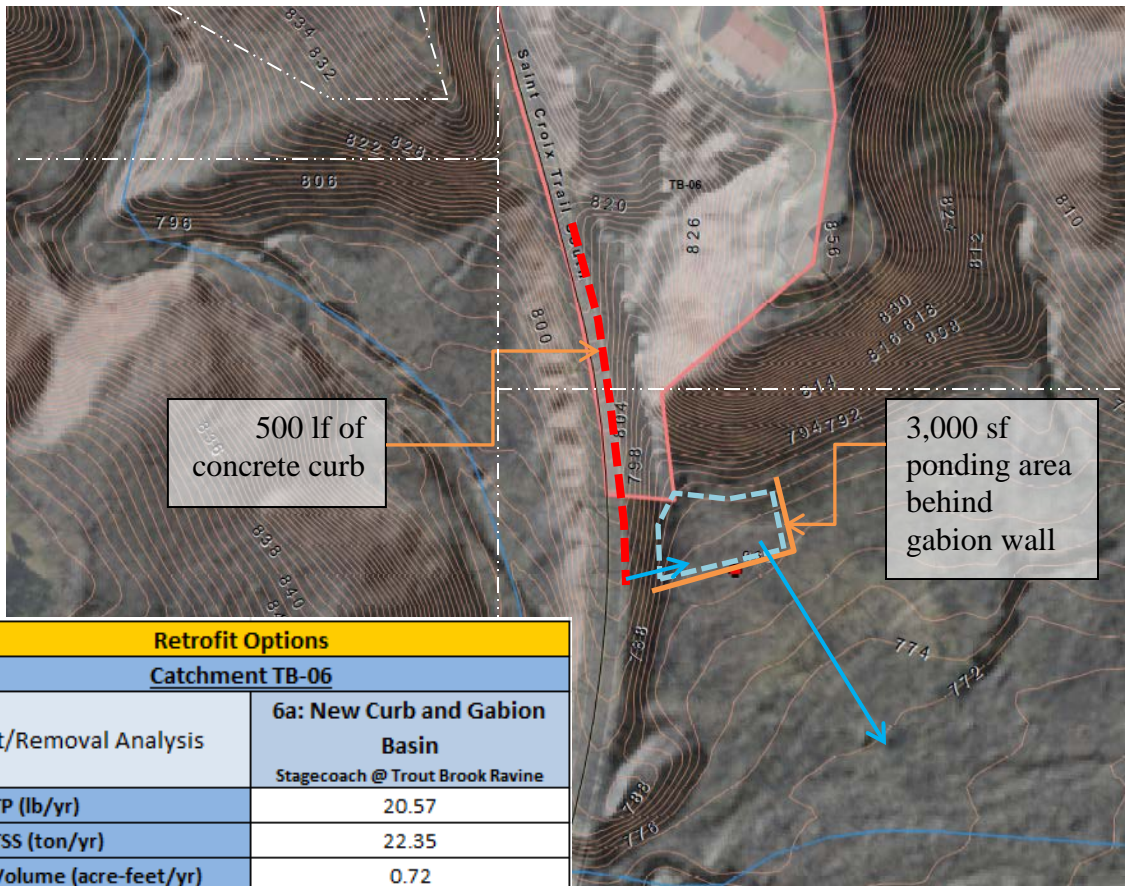

Retrofit Options		
Catchment TB-06		
Cost/Removal Analysis		6a: New Curb and Gabion Basin
		Stagecoach @ Trout Brook Ravine
Treatment	TP (lb/yr)	20.57
	TSS (ton/yr)	22.35
	Volume (acre-feet/yr)	0.72
	Number of BMP's	1
Cost	Materials/Labor/Design	\$53,480.55
	Promotion & Admin Costs	\$3,000
	Probable Project Cost	\$56,481
	Annual O&M	\$200
	30-yr Cost/lb-TP/yr	\$101
	30-yr Cost/ton-TSS/yr	\$93

Catchment TB-10



CATCHMENT DESCRIPTION

Catchment TB-10 is along Oakgreen Ave S near 60th St. It's a very large catchment, but with shallow grades in the upper catchment before flows cross Oakgreen Ave to the gully area. Historical aeriels seem to show that the majority of erosion occurred prior to 1950; and most new erosion is a result of larger rain events and infrequent groundwater issues.

Repairs could include multiple smaller basins near Oakgreen Ave for rate control, but this report only explores armoring the headcuts in the upper ravine area only.

TB-10: BMP 10a – Headcut Repair

Drainage Area – 48.04 acres

Location – Near Intersection of Oakgreen Ave and 60th St S, TB-10

Property Ownership –Private

Rank
12 of 12

Description – Repair headcuts with gabions and vegetative armor in upper ravine.

Upper ravine has several smaller headcuts that could be repaired by a 30LF gabion, 1 course high, and revegetating the side slopes. This would be a fairly straight-forward repair and would be similar to the TB-01 and TB-03 practices. Additional volume control was seen as an alternative, but the costs were much less expensive to just armor the headcuts for such a small pollutant load reduction.

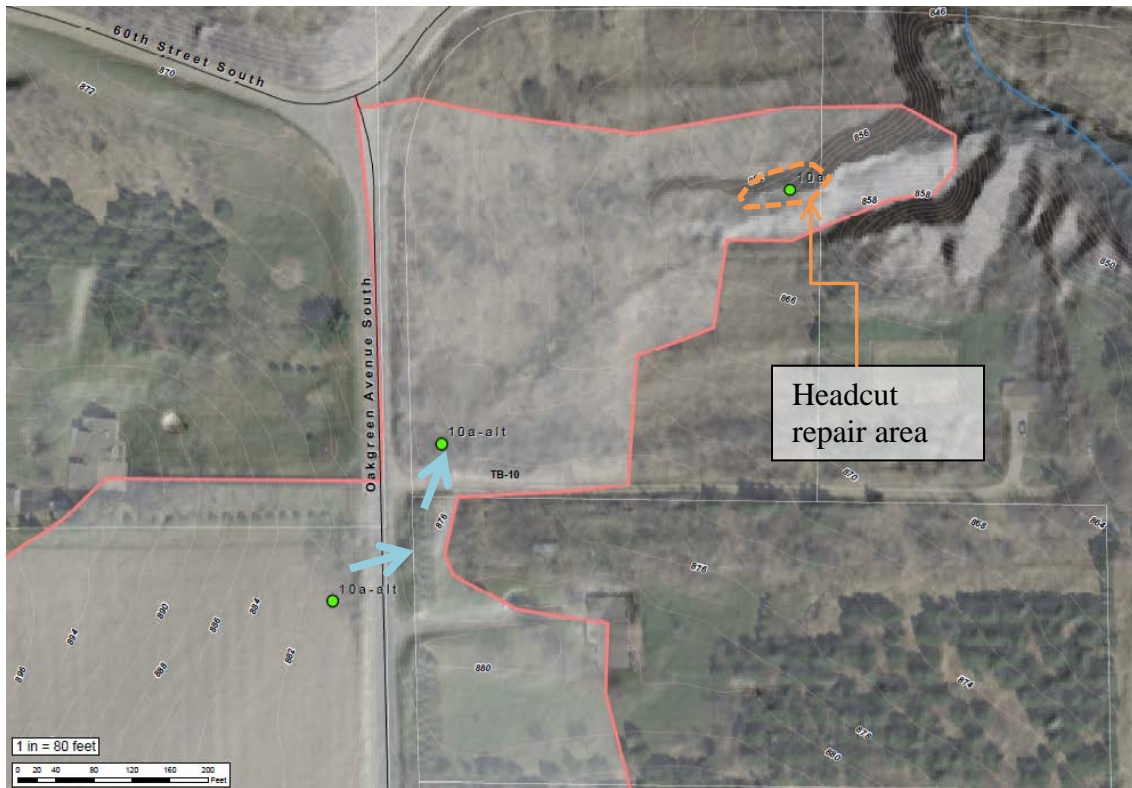

Retrofit Options		
Catchment TB-10		
Cost/Removal Analysis		10a: Headcut Repair Lingenfelter Ravine
Treatment	TP (lb/yr)	0.53
	TSS (ton/yr)	0.6
	Volume (acre-feet/yr)	0.0
	Number of BMP's	1
Cost	Materials/Labor/Design	\$12,194.00
	Promotion & Admin Costs	\$750
	Probable Project Cost	\$12,944
	Annual O&M	\$75
	30-yr Cost/lb-TP/yr	\$956
	30-yr Cost/ton-TSS/yr	\$817

Catchment TB-13

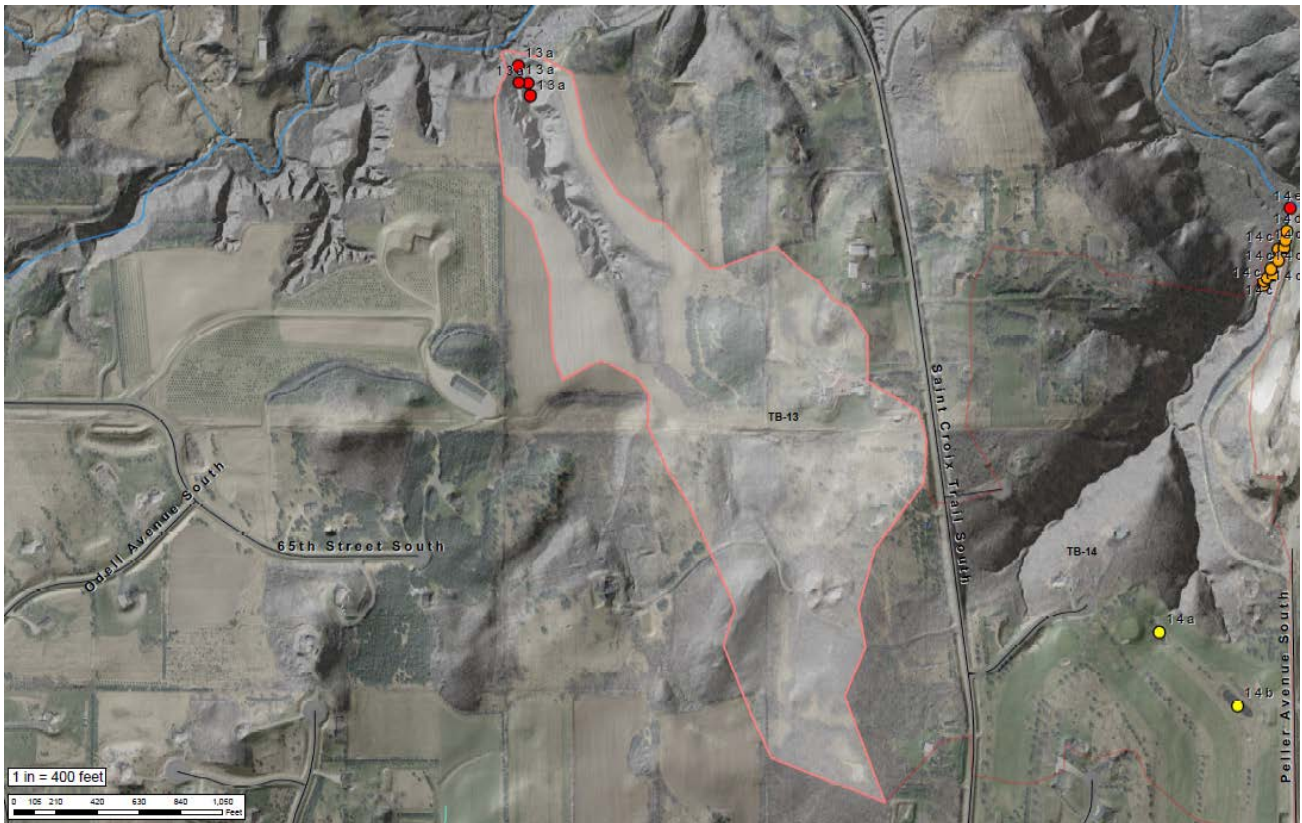

CATCHMENT DESCRIPTION

Catchment TB-13 is very large and runs parallel to St Croix Trail near 65th St S. Historical aerials show that the majority of erosion occurred prior to 1950; and most new erosion is a result of larger rain events and infrequent groundwater issues. Erosion in the ravine channel appears to be downcutting through old sediment deposits, and sideslope erosion in the lower 100-200 feet of channel appears to be a combination of groundwater and sandy soil interactions, exacerbated by channel instability in some areas.

Repairs would be limited to the lower 100' feet of channel; where most of the focus would be on stabilizing the side slopes where groundwater and sandy soil interactions are creating the majority of the issues.

TB-13: BMP 13a – Headcut Repair

Drainage Area – 72.02 acres

Location – Between St Croix Trail and 65th St S, TB-13

Property Ownership –Private



Description – Repair side slopes with gabions and vegetative armor in lower ravine. Practice ranks fairly high due to higher amount of recent erosion and lower repair costs.

Lower 100’ of the ravine has several areas of bank sloughing from groundwater and sandy soil interactions. Slopes and toe could be stabilized by 1 course of gabion wall (60LF) and vegetative restoration. Clearing of 0.33 to 0.5 acres of trees and buckthorn would create more light availability for new vegetation to take hold. Three riprap checks could be installed in the channel to prevent further headcutting, but further analysis should be performed on the channel bed composition before installing any in-channel practices.



Retrofit Options		
Catchment TB-13		
Cost/Removal Analysis		13a: Bank Stabilization and Headcut Repair Reynolds Ravine
Treatment	TP (lb/yr)	12.63
	TSS (ton/yr)	14.8
	Volume (acre-feet/yr)	0.0
	Number of BMP's	4
Cost	Materials/Labor/Design	\$35,524.00
	Promotion & Admin Costs	\$2,250
	Probable Project Cost	\$37,774
	Annual O&M	\$67
	30-yr Cost/lb-TP/yr	\$105
	30-yr Cost/ton-TSS/yr	\$89

Catchment TB-14



CATCHMENT DESCRIPTION

Catchment TB-14 is very large and runs from the Afton Alps Golf Course to the Afton Alps Parking Lot. Historical aerials show that the majority of major erosion occurred prior to 1950, with a second and third wave of major erosion resulting from the initial golf course development (circa 1960) as well as the recent storm sewer additions that discharge from the Afton Alps entrance road (2015).

The ravine channel bottom appears to be relatively stable since much of the ravine channel is large cobble with some bedrock exposures. Most erosion observed is from bank losses. Correction in this ravine should be similar to in-stream management techniques since the flows behave more like a river than an ephemeral gully. Many of the bank losses can be corrected by minor thalweg adjustments to prevent undercutting and mass wasting. Other erosion can be prevented from adjustments to the new pipe outfalls in the lower third of the ravine (new pipes that discharge Afton Alps entrance road).

TB-14: BMP 14a – Iron Enhanced Sand Filter

Drainage Area – 6.97 acres

Location – Afton Alps Golf Course, upper ravines TB-14

Property Ownership –Private

Rank
10 of 12

Description – Iron Enhanced Sand Filter bench retrofit alongside of existing storm pond.

Install new outlet structure to allow raising the pond outlet 6-9” and the emergency overflow berm by 1.5’ (EOF storage area expanded by 1600 sf). Up to 120 lf (480sf/960cf) of iron enhanced sand media can be installed along north edge of basin. New draintile for the IESF bench will have to be trenched to the ravine. Pollution reduction would be primarily for soluble phosphorus, as the existing pond volume is already sized for adequate TSS reductions. The ranking is low relative to other practices in this study, but the cost per pound of TP is in line with a retrofit of this type. The overall cost/benefit still makes it a higher ranking project in most other urban SWAs.



Retrofit Options		
Catchment TB-14		
Cost/Removal Analysis		14a: Pond IESF Retrofit Afton Alps Golf Course - west
Treatment	TP (lb/yr)	1.25
	TSS (ton/yr)	0.48
	Volume (acre-feet/yr)	0.07
	Number of BMP's	1
Cost	Materials/Labor/Design	\$13,316.00
	Promotion & Admin Costs	\$2,250
	Probable Project Cost	\$15,566
	Annual O&M	\$167
	30-yr Cost/lb-TP/yr	\$548
	30-yr Cost/ton-TSS/yr	\$1,422

TB-14: BMP 14b – Iron Enhanced Sand Filter

Drainage Area – 11.59 acres

Location – Afton Alps Golf Course, upper ravines TB-14

Property Ownership –Private

**Rank
9 of 12**

Description – Iron Enhanced Sand Filter bench retrofit alongside of existing storm pond.

Install new outlet structure to allow raising the pond outlet 6-9” and the emergency overflow berm by 1.5’ (EOF storage area expanded by 6700 sf). Up to 160 lf (640sf/1280cf) of iron enhanced sand media can be installed along north edge of basin. New draitile for the IESF bench will have to be trenched to the ravine. Pollution reduction would be primarily for soluble phosphorus, as the existing pond volume is already sized for adequate TSS reductions. The ranking is low relative to other practices in this study, but the cost per pound of TP is in line with a retrofit of this type. The overall cost/benefit still makes it a higher ranking project in most other urban SWAs.

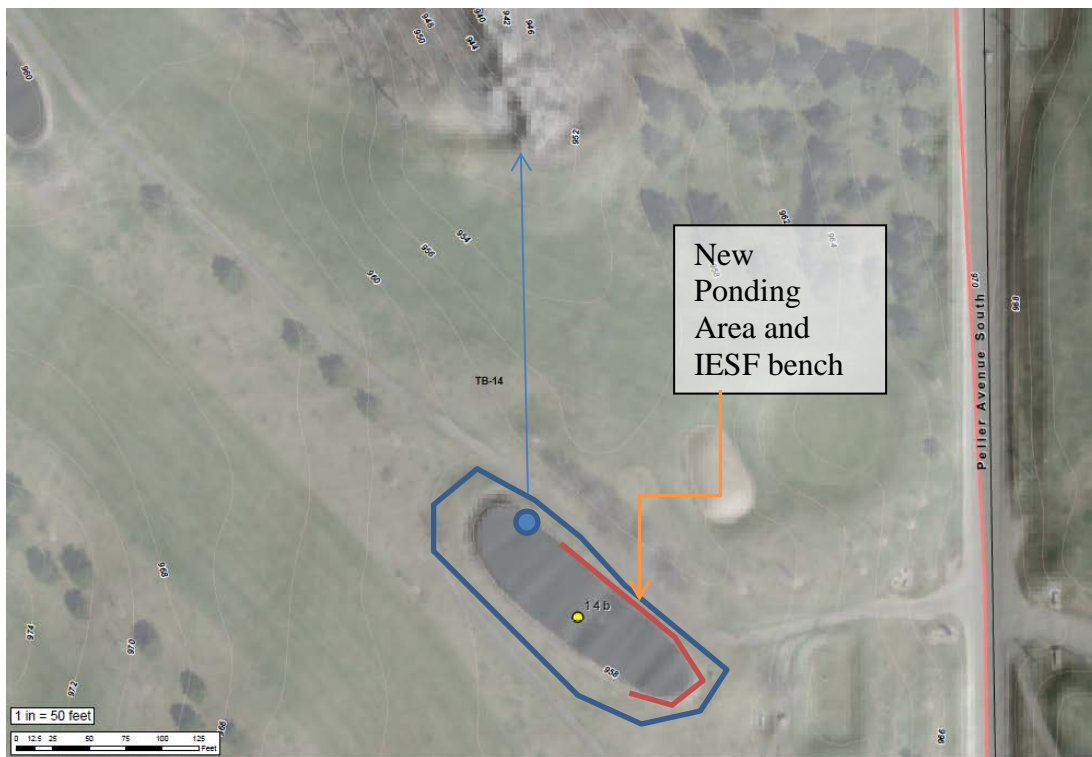

Retrofit Options		
Catchment TB-14		
Cost/Removal Analysis		14b: Pond IESF Retrofit Afton Alps Golf Course - east
Treatment	TP (lb/yr)	1.60
	TSS (ton/yr)	0.59
	Volume (acre-feet/yr)	0.17
	Number of BMP's	1
Cost	Materials/Labor/Design	\$16,021.00
	Promotion & Admin Costs	\$2,250
	Probable Project Cost	\$18,271
	Annual O&M	\$200
	30-yr Cost/lb-TP/yr	\$506
	30-yr Cost/ton-TSS/yr	\$1,371

TB-14: BMP 14c+d – Thalweg and Pipe Corrections

Drainage Area – 101.5 acres

Location – Lower Afton Alps Ravine, TB-14

Property Ownership – Private/Public (Afton Alps State Park)



Description – Add pipe extension to one pipe to redirect flow. Use existing rock and trees in ravine to redirect thalweg away from undercut banks to prevent further losses.

Install angled pipe extension to Outfall B to redirect flows away from banks across ravine. For all points labelled 14c, utilize existing rock in ravine (using CCM crew or contractors) to install a series of rock vanes and cross vanes to redirect thalweg toward center of channel (avoiding eroded banks at these locations). Utilize fallen trees to stabilize toes or promote settling of sediment. At 14d (Outfall A), excavate sediment accumulation of the half-buried outlet pipe. This pipe only took 2 years to become half covered, so controlling erosion and excavating sediment should happen very soon to prevent complete blockage of this pipe. The estimate for this project did account for a few trucks worth of imported riprap of considerable size and haul away of excavated sediment.

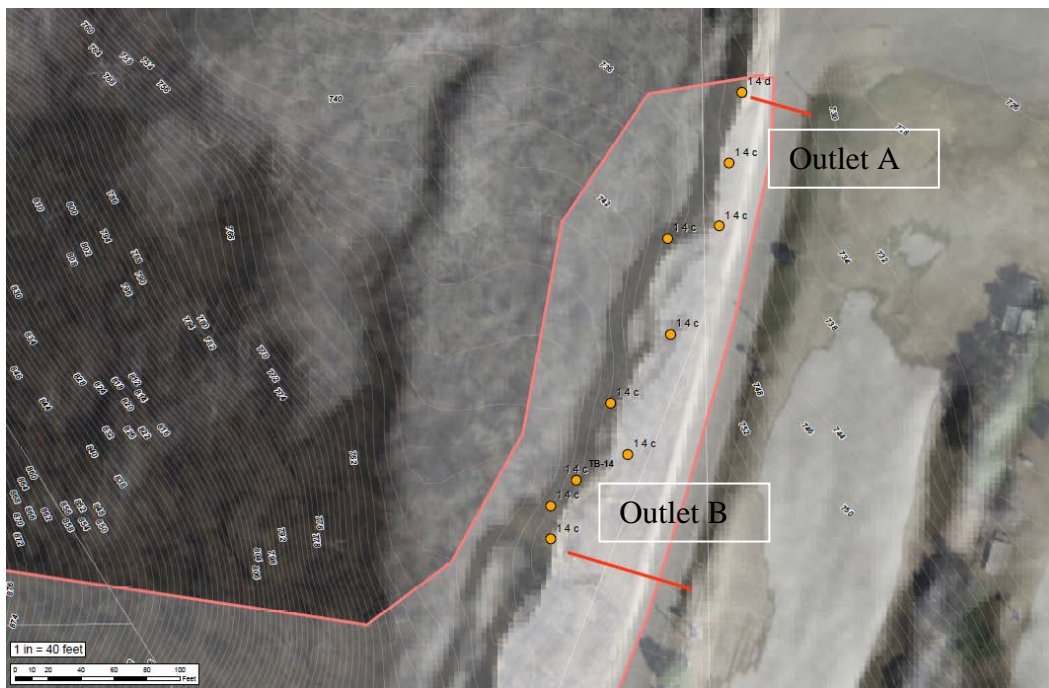

Retrofit Options		
Catchment TB-14		
Cost/Removal Analysis		14c + d: Thalweg and Pipe Corrections Lower Afton Ravine
Treatment	TP (lb/yr)	7.01
	TSS (ton/yr)	7.0
	Volume (acre-feet/yr)	WQV (ac-ft)
	Number of BMP's	10
Cost	Materials/Labor/Design	\$30,000.00
	Promotion & Admin Costs	\$2,250
	Probable Project Cost	\$32,250
	Annual O&M	\$75
	30-yr Cost/lb-TP/yr	\$164
	30-yr Cost/ton-TSS/yr	\$164

TB-14: BMP 14e– Gabion Sediment Basin

**Rank
5 of 12**

Drainage Area – 108 acres

Location – Lower Afton Alps Ravine, outlet of TB-14

Property Ownership – Private

Description – Currently, about 3000-4000 cf of sediment lay at the bottom of the ravine. Much of this current deposit looks to be a result of the new pipes that have been installed and are causing bank erosion. For modelling, we assumed 50% of the annual ravine load is exported to Trout Brook. To capture even 50% of this exported load, a practice of considerable size would need to be installed and would need to be capable of storing 10-20 years of sediment before expected cleanout would occur. It would also need to be capable of passing a large volume of water quickly. The gabion sediment wall fits these parameters nicely.

Install 240 LF of gabion wall (1 course high) to trap sediment deposited from ravine. Storage capacity is 4,000 sf (8,000 cf). The gully is currently estimated to export 1,293 cf of TSS every year (BWSR Gully Estimator and RUSLE, conservatively high estimate for storage accounting). This is without repairs to the gully. If 50% is captured annually, it would be 12.4 years until expected cleanout. This could vary widely, but a reasonable expectation would be that cleanout would need to occur every 8-10 years to be safe, and target cleanout depth would need to be 50-70% capacity of the basin. Techniques could be used to elongate the flowpath through the basin to ensure even distribution of sediment occurs, prolonging the life of the practice. An earthen berm with an armored overflow would be less expensive to install, but would be susceptible to permanent pooling as you would lose the ability to weep large volumes of water over a deconcentrated outlet as with a gabion berm.

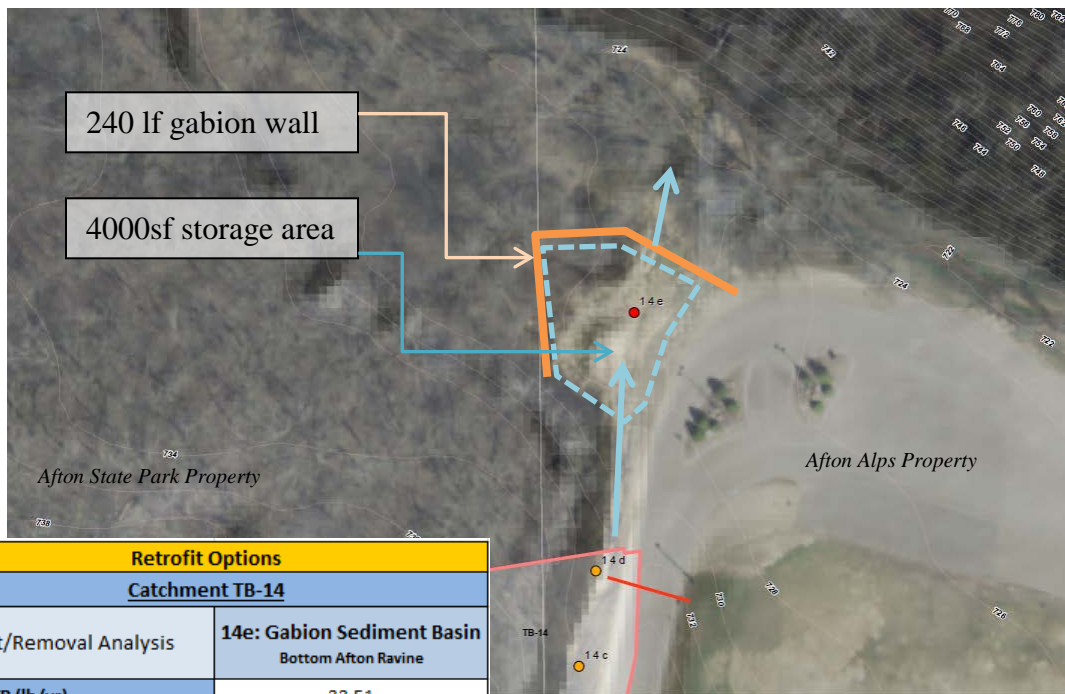

Retrofit Options		
Catchment TB-14		
Cost/Removal Analysis		14e: Gabion Sediment Basin Bottom Afton Ravine
Treatment	TP (lb/yr)	33.51
	TSS (ton/yr)	33.5
	Volume (acre-feet/yr)	0.0
	Number of BMP's	1
Cost	Materials/Labor/Design	\$85,924.00
	Promotion & Admin Costs	\$3,000
	Probable Project Cost	\$88,924
	Annual O&M	\$833
	30-yr Cost/lb-TP/yr	\$113
	30-yr Cost/ton-TSS/yr	\$113

Catchment TB-15



CATCHMENT DESCRIPTION

Catchment TB-15 has a relatively small drainage area compared to the amount of erosion observed. This is a very active gully, with very large amounts of the upper ravine bank areas being eroded annually. Most of the soil loss looks fairly recent on the side slopes. Historical aerials show that much of the major erosion occurred prior to 1950 and the catchment size may have been reduced due to diversions away from this gully (from the west). To explain the losses occurring today, we can only conclude that once the process of down-cutting and toe failure hit a critical depth, a negative feedback loop of undercutting steep, sandy, bare slopes begins which becomes hard to stop.

The ravine channel bottom appears to be continually down-cutting through recent and historic deposits, and exports through a 48" pipe that outlets to a railroad embankment area on the St Croix River. Not much settling can occur since the pipe outlet at the river is at the bottom of a sloped area (looks like a basin but has negative slope).

TB-15: BMP 15a+b – Upper Ravine Stabilization

Drainage Area – 6.50 acres

Location – Northwest of 87th St S and Quadrant Ave S, upper ravine TB-15

Property Ownership –Private



Description – Combination of flow diversion, toe stabilization, cross vanes to redirect flow in channel, increasing woodland vegetation, and hydroseeding bare slopes.

Divert flow from the northern catchment. There is a 12” pipe that drains a small portion of farm field that is actively cropped. This flow can easily be diverted in a new ditch (300lf) that flows to the west, to join up with a safer flow network. The forest above the ravines is red pine with barely any understory. Thinning of this pine stand and revegetation should occur to promote upstream infiltration. In this section of channel, there are a lot of fallen trees that can be used to stabilize the toe. Use multiple cross vanes or check dams to keep channel flow diverted from bank toes. Add 400 sf infiltration basin to east ravine reach and armor headcuts with combination of checkdams and cross vanes. Hydroseed 15,000sf of bare slopes. This cost estimate appears low, but it assumes that 15c will be constructed in tandem and the costs of accessing the site are minimized. It is also assumed that most of the toe stabilization material will be from trees already in the ravine (brush packing and shrub planting the toes). Even if the cost of this installation were doubled, it would still rank as a top 5 practice.

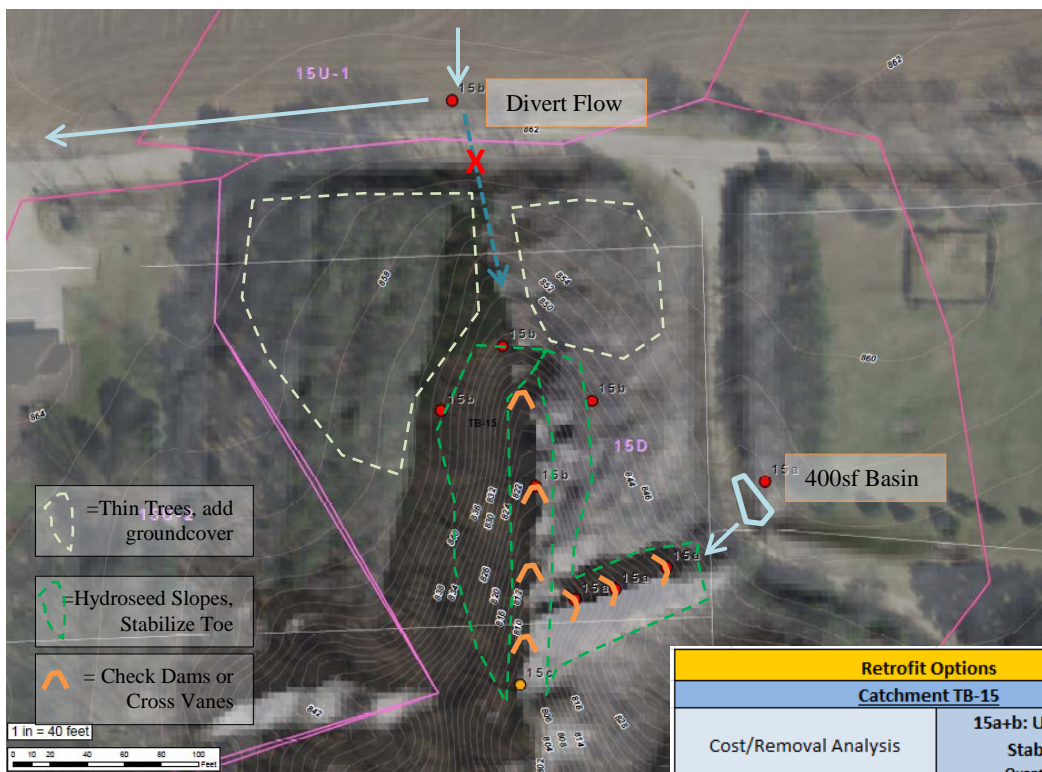

Retrofit Options		
Catchment TB-15		
Cost/Removal Analysis		15a+b: Upper Ravine Stabilization Quant Ave Ravine
Treatment	TP (lb/yr)	26.06
	TSS (ton/yr)	29.2
	Volume (acre-feet/yr)	0.6
	Number of BMP's	10
Cost	Materials/Labor/Design	\$44,840.00
	Promotion & Admin Costs	\$1,500
	Probable Project Cost	\$46,340
	Annual O&M	\$133
	30-yr Cost/lb-TP/yr	\$64
	30-yr Cost/ton-TSS/yr	\$58

TB-15: BMP 15c – Lower Ravine Thalweg Corrections

**Rank
8 of 12**

Drainage Area – 11.6 acres

Location – Northwest of 87th St S and Quadrant Ave S, lower ravine TB-15

Property Ownership –Private

Description – Use in-stream management techniques to divert thalweg away from undercut banks and slow velocities.

There are several points in the lower ravine where the side banks are being undercut. At several other locations there is excessive down-cutting through previous sediment deposits and existing soils. Use in-stream techniques at points shown to control the thalweg and divert it away from cutting banks. There are other locations that had some minor headcutting, but a full catalog of these locations was not possible for this analysis. This cost analysis only models an average bank cut volume along the lower channel, and assumes 50% of this volume will be reduced by redirection of the thalweg only. Bank revegetation is not recommended in the cost analysis as it is assumed losses will be minimized through flow redirection. Bank losses in the channel and lower ravine are likely larger than calculated and these corrections may rank much higher upon closer inspection. Bank stabilization may still be need in a few select spots.

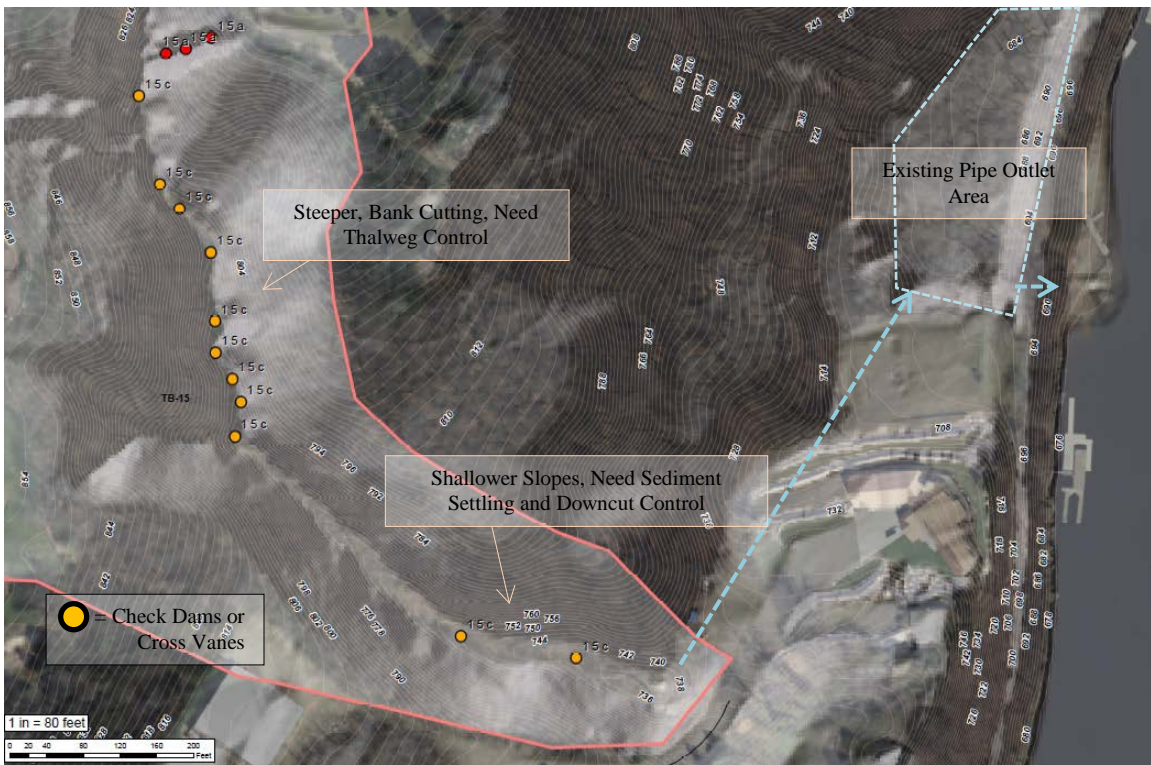

Retrofit Options		
Catchment TB-15		
Cost/Removal Analysis		
15c: Lower Ravine Thalweg Corrections		
Quant Ave Ravine		
Treatment	TP (lb/yr)	5.60
	TSS (ton/yr)	6.6
	Volume (acre-feet/yr)	0.0
	Number of BMP's	10
Cost	Materials/Labor/Design	\$43,333.60
	Promotion & Admin Costs	\$2,250
	Probable Project Cost	\$45,584
	Annual O&M	\$133
	30-yr Cost/lb-TP/yr	\$295
	30-yr Cost/ton-TSS/yr	\$250

Intentionally Blank

Appendix A: Methods

Methods

Selection of Subwatershed

Many factors are considered when choosing which subwatershed to analyze for stormwater retrofits. Water quality monitoring data, non-degradation report modeling, and TMDL studies are just a few of the resources available to help determine which water bodies are a priority. Stormwater retrofit analyses supported by a Local Government Unit with sufficient capacity (staff, funding, available GIS data, etc.) to greater facilitate the process also rank highly. For some communities a stormwater retrofit analysis complements their MS4 stormwater permit. The focus is always on a high priority waterbody.

For this analysis, areas draining directly to the three priority water bodies with little or no pretreatment of runoff were chosen for study. White Bear Lake, Lost Lake, and Lake Washington are not listed on the EPA's 303(d) list of impaired water bodies but they are a high priority for the watershed district to stay below thresholds for impairment in lakes. Identifying areas that receive little to no pretreatment become a priority as these areas typically have a large impact on lake water quality.

Stormwater runoff from impervious surfaces like pavement and roofs can carry a variety of pollutants. While stormwater treatment to remove these pollutants is adequate in some areas, other areas were built before modern-day stormwater treatment technologies and requirements or have undersized treatment devices.



Stormwater Retrofit Analysis Methods

The process used for this analysis is outlined in the following pages and was modified from the Center for Watershed Protection's Urban Stormwater Retrofit Practices, Manuals 2 and 3 (Schueler, 2005, 2007). Locally relevant design considerations were also incorporated into the process (Minnesota Stormwater Manual).

Step 1: Retrofit Scoping

Retrofit scoping includes determining the objectives of the retrofits (volume reduction, target pollutant, etc.) and the level of treatment desired. It involves meeting with local stormwater managers, city staff and watershed management organization members to determine the issues in the subwatershed. This step also helps to define preferred retrofit treatment options and retrofit performance criteria. In order to create a manageable area to analyze in large subwatersheds, a focus area may be determined.

In this analysis, the focus area was all ravines that outlet directly to Trout Brook. Included are areas of residential and agricultural land uses, as well as undeveloped areas of mature woodlands. The subwatershed was divided into subcatchments using a combination of existing subwatershed mapping data, stormwater infrastructure maps, and observed topography. Using the Stream Power Index methodology, we identified several ravines with the greatest erosion potential and field verified these results. This study identified only 15 subcatchments worth modelling, and later reduced this total to 7 after several rounds of field verification and preliminary erosion estimates were created. Only the ravines with visible disturbances and currently active erosion were included in this study.

The targeted pollutant for this study was Total Phosphorus (TP), though Total Suspended Solids (TSS) and Water Quality Volume (WQV) were also modeled and reported. Total Phosphorus was chosen as the primary target pollutant. Total Suspended Solids (TSS) were also reported since it was the primary pollutant modelled in RUSLE 2 and the BWSR Pollution Reduction Spreadsheets and was needed to obtain a value for TP reductions. Volume of stormwater was tracked throughout this study because it is necessary for pollutant loading calculations and potential retrofit project considerations.

Step 2: Desktop Retrofit Analysis

The desktop analysis involves computer-based scanning of the subwatershed for potential retrofit catchments and/or specific sites. This step also identifies areas that don't need to be analyzed because of existing stormwater infrastructure or disconnection from the target water body. Accurate GIS data are extremely valuable in conducting the desktop retrofit analysis. Some of the most important GIS layers include: 2-foot or finer topography, hydrology, soils, watershed/subwatershed boundaries, parcel boundaries, high-resolution aerial photography and the stormwater drainage infrastructure (with invert elevations).

Desktop retrofit analysis features to look for and potential stormwater retrofit projects.

<i>Feature</i>	<i>Potential Retrofit Project</i>
Existing Ponds	Add storage and/or improve water quality by excavating pond bottom, modifying riser, raising embankment, and/or modifying flow routing.
Open Space	New regional treatment (pond, bioretention).
Roadway Culverts	Add wetland or extended detention water quality treatment upstream.
Outfalls	Split flows or add storage below outfalls if open space is available.

Conveyance system	Add or improve performance of existing swales, ditches and non-perennial streams.
Large Impervious Areas (campuses, commercial, parking)	Stormwater treatment on site or in nearby open spaces.
Neighborhoods	Utilize right of way, roadside ditches, curb-cut rain gardens, or filter systems before water enters storm drain network.

Step 3: Retrofit Reconnaissance Investigation

After identifying potential retrofit sites through this desktop search, a field investigation was conducted to evaluate each site and identify additional opportunities. During the investigation, the drainage area and stormwater infrastructure mapping data were verified. Site constraints were assessed to determine the most feasible retrofit options as well as eliminate sites from consideration. The field investigation may have also revealed additional retrofit opportunities that could have gone unnoticed during the desktop search.

Step 4: Treatment Analysis/Cost Estimates

Sites most likely to be conducive to addressing the cities' and watershed district's goals and appear to have simple-to-moderate design, installation, and maintenance were chosen for a cost/benefit analysis. Estimated costs included design, installation, and maintenance annualized across a 30-year period. Estimated benefits included are pounds of phosphorus and total suspended solids removed, though projects were ranked only by cost per pound of phosphorus removed annually.

Treatment analysis

Several models had to be combined to form a clear picture of erosion losses and treatment values for proposed BMPs. Since most runoff models only account for sheet and rill erosion and not losses from bank failure or concentrated flow paths, we had to combine the results from WinSLAMM and RUSLE2 (overland flow models) with the results from the BWSR Pollution Reduction Spreadsheets (gully and shoreline erosion calculators, for areas of concentrated flow).

If the land use was suburban in nature and contained impervious surfaces that were deemed critical to increasing runoff, removals were estimated using the stormwater model WinSLAMM. WinSLAMM uses an abundance of stormwater data from the upper Midwest and elsewhere to quantify runoff volumes and pollutant loads from urban areas. It is useful for determining the effectiveness of proposed stormwater control practices. It has detailed accounting of pollutant loading from various land uses, and allows the user to build a model "landscape" that reflects the actual landscape being considered. The user is allowed to place a variety of stormwater treatment practices that treat water from various parts of this landscape. It uses rainfall and temperature data from a typical year, routing stormwater through the user's model for each storm.

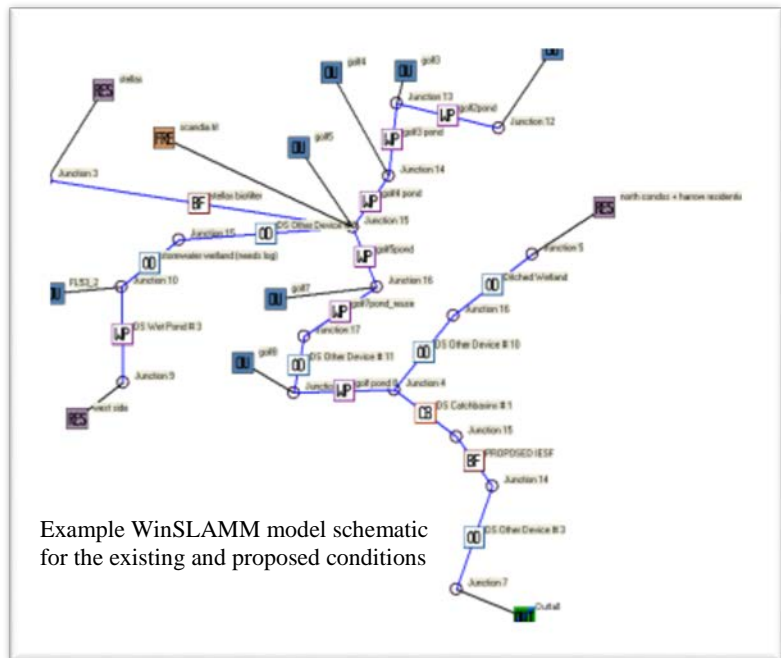

The initial step was to create a “base” model which estimated pollutant loading from each catchment in its present-day state without taking into consideration any existing stormwater treatment. To accurately model the land uses in each catchment, we delineated each land use in each catchment using geographic information systems (specifically, ArcMap), and assigned each a WinSLAMM standard land use file. A site specific land use file was created by adjusting total acreage and accounting for local soil types (all soils were modeled as silt in this analysis). This process resulted in a model that included estimates of the acreage of each type of source area (roof, road, lawn, etc.) in each catchment. For certain source areas critical to our models we verified that model estimates were accurate by calculating actual acreages in ArcMap, and adjusting the model acreages if needed.

Once the “base” model was established, an “existing conditions” model was created by incorporating any existing stormwater treatment practices in the catchment. For example, street cleaning with mechanical or vacuum street sweepers, rain gardens, stormwater treatment ponds, and others were included in the “existing conditions” model if they were present in the catchment.

Finally, each proposed stormwater treatment practice was added to the “existing conditions” model and pollutant reductions were generated. Because neither a detailed design of each practice nor in-depth site investigation was completed, a generalized design for each practice was used. Whenever possible, site-specific parameters were included. Design parameters were modified to obtain various levels of treatment. It is worth noting that we modeled each practice individually, and the benefits of projects may not be additive, especially if serving the same area. Reported treatment levels are dependent upon optimal site selection and sizing.

WinSLAMM stormwater model inputs

Current File Data

SLAMM Data File Name:

Site Descript:

Edit Seed: -42

Edit Rain File: C:\WinSLAMM Files\Rain Files\MN Minneapolis 59.RAN

Edit Start Date: 01/02/59 Winter Season Range
Edit End Date: 12/28/59 Start of Winter (mm/dd) 11/12 End of Winter (mm/dd) 03/18

Edit Pollutant Probability Distribution File: C:\WinSLAMM Files\WL_GEO03.ppd

Edit Runoff Coefficient File: C:\WinSLAMM Files\WL_SL06 Dec06.rsxx

Edit Particulate Solids Concentration File: C:\WinSLAMM Files\10.1 WL_AVG01.pscx

Edit Street Delivery File (Select LU): C:\WinSLAMM Files\WL_Res and Other Urban Dec06.std

Residential LU Other Urban LU
 Institutional LU Freeways
 Commercial LU
 Industrial LU

Edit Source Area PSD and Peak to Average Flow Ratio File: C:\WinSLAMM Files\NURP Source Area PSD Files.csv

Use Cost Estimation Option

RUSLE, RUSLE2, and the BWSR Pollution Reduction Spreadsheets

In areas where the landuse was primarily agricultural or mature woodlands, RUSLE2 was used to model the overland flow. In the unique case of TB-14 (where sideslope and woodland losses had to be accounted for in order to design an end-of-channel practice), RUSLE1 was used to account for overland flow since we could not reliably change the C values to emulate a woodland landcover in RUSLE2. Manual calculations were then used to emulate losses from one slope condition to another, and from one ravine condition to another, until an end result was estimated for the outlet of the ravine.

Since TP is not calculated in RUSLE1 or RUSLE2, TSS values from these models were then input into the BWSR Pollution Reduction Spreadsheets to obtain a TP reduction value (based on pre and post-installation conditions). The GULLY tab in the BWSR Spreadsheet was used to obtain TP values by estimating the volume of soil lost over 'X' amount of years in the gully. Estimates of duration ranged from 1-100 years, depending on local knowledge, observed condition, and aerial inspection. A unique duration value of 1-100 years was identified for each ravine, and values erred on the conservative side. See below for specific methodologies for each subcatchment.

TB-01 Methods

This load was calculated using the BWSR Spreadsheets (GULLY tab). Eroded volume being prevented on an annual basis in the repair zone was counted as the load reduction. Pollution reductions provided by WCD engineer and were calculated at a time just previous to the creation of this report.

TB-03 Methods

This load was calculated using the BWSR Spreadsheets (GULLY tab), WinSLAMM was not used since the catchment area was fairly small, no basins were being constructed, and the majority of erosion seemed to be a result of groundwater and sandy soils rather than surface flow alone. Eroded volume being prevented on an annual basis in the repair zone was counted as the load reduction. Volume voided was 1400 cf over a composite average duration of 65 years.

TB-04 Methods

This load was calculated using WinSLAMM and the BWSR Spreadsheets (GULLY tab). Land was classified Suburban, and impervious surfaces were delineated individually. All loads were calculated separately but the upper basin west of Osgood Ave was calculated directly in WinSLAMM. Inputs were 1,500 sf surface area, 6" draintile, D soils, 12" ponding depth.

For the gabion sediment basin below Osgood Ave, the total storage available at 2' depth was used to calculate how much storage was available. It was assumed that half of this depth (1' depth) would be the cleanout threshold. This depth was used to calculate the volume and then calculate how many years it would take to fill the basin, based on 100% of the WinSLAMM sediment delivery values and 25% of the gully erosion delivery values above this location.

At the 2 remaining headcut repairs downstream, the eroded volume being prevented on an annual basis in the headcut zone was counted as the load reduction (50% credit was given to be conservative). Volume voided was 3800 cf over an assumed duration of 30 years (when area became more developed and impervious).

TB-06 Methods

This load was calculated using WinSLAMM and the BWSR Spreadsheets (GULLY tab). Land was classified Residential, and impervious surfaces were delineated individually. The gully was assumed to have lost 8,000cf of volume over 20 years. The total storage available behind the gabion basin wall was set at a 2' depth and was used to calculate how much storage was available. It was assumed that half of this depth (1' depth) would be the cleanout threshold. This depth was used to calculate the volume and then calculate how many years it would take to fill the basin.

The combined pollutant load reduction for the practice is the sum of the practice reductions and the losses avoided from redirecting flow away from the gully. 100% of the WinSLAMM sediment delivery values above the ravine were added to 25% of the gully erosion delivery values above this location (assuming some erosion will still occur). 50% of this composite value is the load reduction from the practice itself, and this value was added to the assumed 75% load reduction from re-routing the majority of water flow away from the ravine (thereby minimizing future erosion).

TB-10 Methods

This load was calculated using the BWSR Spreadsheets (GULLY tab). Since the majority of the catchment flows to a large area of 1-2% slope to the west of Oakgreen Ave, it was assumed that only a very large event would cause major erosion and major settling of sediment typically occurs at this point. Aerial inspection shows not much change has occurred to the shape of the gully or the type of landcover, so a 100 year duration was given for the calculations. Volume voided was 1,125 cf.

TB-13 Methods

This load was calculated using the BWSR Spreadsheets (GULLY tab). Through historic aerial inspection, it appears the majority of erosion occurred in the 1920's to the 1940's. The general shape of the gully has not changed much since. Recent erosion appears limited to the groundwater seeps along the sideslopes, in the lower 100' of the gully, as well as near-channel erosion that is downcutting through old deposits (lower 275' LF of channel). Volume voided in the repair area was used for this calculation (27,000 cf) and was estimated at a 50 year duration (when aerials show less erosion and more cover present).

TB-14 Methods

The Iron Enhanced Sand Filters were calculated using WinSLAMM. The existing and proposed pond areas were used, and a 50% credit for dissolved phosphorus reduction was applied on top of the WinSLAMM reductions. This value was added to a modest credit for reduced erosion along the first 100' of their respective gullies.

The remaining gully base-load had to be calculated using RUSLE1 and the BWSR Spreadsheet (GULLY tab). The entire gully was broken into 20 subcatchments, with flow lengths and slopes recorded for each. Each subcatchment was modelled in RUSLE1 since it was difficult to find an analog to the land cover and slope conditions in RUSLE2. A custom C Factor of 0.08 was chosen to represent the basic forest condition on these slopes. It felt like an appropriate intermediate value to choose after reviewing other documentation on C Factor selection. Each catchment result was input into the BWSR Spreadsheet (SHEET & RILL tab) to get a phosphorus value based on their respective acreages. The 20 subcatchment results were then aggregated into subgroups (determined by position within the ravine). The TSS export value for each upstream subgroup was then added to the next downstream subgroup to account for reductions in sediment delivery (% slope being the driving factor for settling). The final export value from the ravine was used to calculate anticipated storage needs behind the gabion sediment basin (similar to TB-06 methods). 50% capture credit was given to the gabion basin for the final pollution reduction estimate.

All credit for in-channel corrections to the thalweg were based 50% of the volume of bank loss at each correction location. 825 cf of soil lost over 5 years at 50% credit is the pollution reduction for all combined thalweg corrections.

TB-15 Methods

The loads for this catchment were a combination of WinSLAMM (upper infiltration basin and diversion only), RUSLE2, and the BWSR Pollution Reduction Spreadsheets. The upper basin was modelled as 400sf, 12" ponding depth, no underdrains, and HSG 'A' soils with an infiltration capacity of 1" per hour (conservative estimate). For all ravine erosion in the upper reach (everything up to and including BMPs 15a and 15b), the eroded volume of the sideslopes was estimated to be 51,850 cf. The duration of loss was estimated to be 30 years, using sandy soils. A 50% reduction was

applied to this value for its long distance to surface water (>1321 ft). No in Channel erosion was calculated at this location within the ravine. All values were input in to the BWSR Spreadsheet (GULLY tab). A 50% reduction of this erosion export value was used to estimate the benefit for restoring the slopes and stabilizing the toe.

The redirection of flow above the ravine head (the field north of the private drive) was modelled using WinSLAMM and 100% credit was given for pollution reductions since 100% of flows from this subcatchment were to be directed away from the ravine permanently.

The lower ravine BMPs (all labelled 15c) were calculated using the BWSR spreadsheet only (SHORELINE tab). It was assumed that if the thalweg could be redirected away from the sidewalls of the ravine where erosion was occurring, then a 50% credit for estimate losses could be applied for pollution reductions. An average volume was estimated to be 7200 cf; with a duration of 30 years for the losses. Only near channel erosion was accounted for in these calculations and no upper slope or woodland erosion was modelled. Therefore the estimate is considered extremely conservative.

Cost Estimates

All estimates were developed using 2017 dollars. Cost estimates were annualized costs that incorporated design, installation, installation oversight, and maintenance over a 30-year period. In cases where promotion to landowners is important, such as rain gardens, those costs were included as well. In cases where multiple, similar projects are proposed in the same locality, promotion and administration costs were estimated using a non-linear relationship that accounted for savings with scale. Design assistance from an engineer is assumed for practices in-line with the stormwater conveyance system, involving complex stormwater treatment interactions, or posing a risk for upstream flooding. It should be understood that no site-specific construction investigations were done as part of this stormwater retrofit analysis, and therefore cost estimates account for only general site considerations.

The costs associated with several different pollution reduction levels were calculated. Generally, more or larger practices result in greater pollution removal. However the costs of obtaining the highest levels of treatment are often prohibitively expensive (see figure). By comparing costs of different treatment levels, the cities and watershed district can best choose the project sizing that meets their goals.

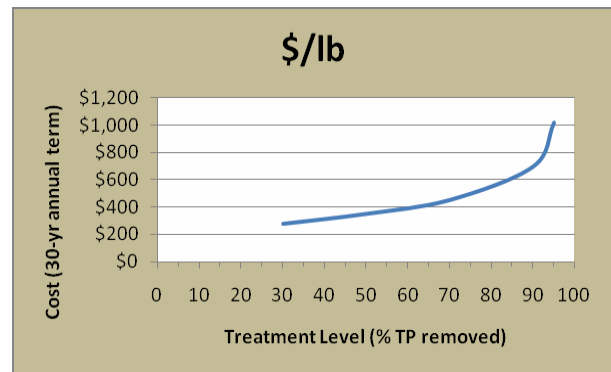

Step 5: Evaluation and Ranking

The cost per pound of phosphorus treated was calculated for each potential retrofit project. Only projects that seemed realistic and feasible were considered. The recommended level was the level of treatment that would yield the greatest benefit per dollar spent while being considered feasible and not falling below a minimal amount needed to justify crew mobilization and outreach efforts. Local officials may wish to revise the recommended level based on water quality goals, finances, or public opinion.

Intentionally Blank

Appendix B: How to Read Catchment Profiles

Intentionally Blank

Catchment Profiles and How to Read Them

The analysis contains pages referred to as “Catchment Profiles.” These profiles provide the most important details of this report, including:

- Summary of existing conditions, including existing stormwater infrastructure, and estimated pollutant export to target water body.
- Map of the catchment
- Recommended stormwater retrofits, pollutant reductions, and costs.

Following all of the catchment profiles (also in the executive summary) is a summary table that ranks all projects in all catchments by cost effectiveness.

To save space and avoid being repetitive, explanations of the catchment profiles are provided below. We strongly recommend reviewing this section before moving forward in the report.

The analyses of each catchment are broken into “base, existing, and proposed” conditions. They are defined as follows:

Existing conditions - Volume and pollutant loadings after already-existing stormwater practices are taken into account.

Proposed conditions - Volume and pollutant loadings after proposed stormwater retrofits.

Analyses were performed at one of two geographic scales, “catchment or network.” They are defined as follows:

BMP Sub-catchment level analyses - Volume and pollutant loads exiting the sub-catchment of the proposed BMP or the proposed Priority Shoreline Catchment. BMP Sub-catchments are then ranked on a cost/Lb Tp/10years and compared to all other proposed practices. This method highlights best BMPs overall, irrespective of sub-catchment location (example; BMP 15c is more cost effective than BMP 3a).

The example catchment profile on the following pages explains important features of each profile.

EXAMPLE Catchment TB-06

HOW TO
READ
CATCHME
NT

Catchment ID
Banner

Catchment Map with existing
stormwater features

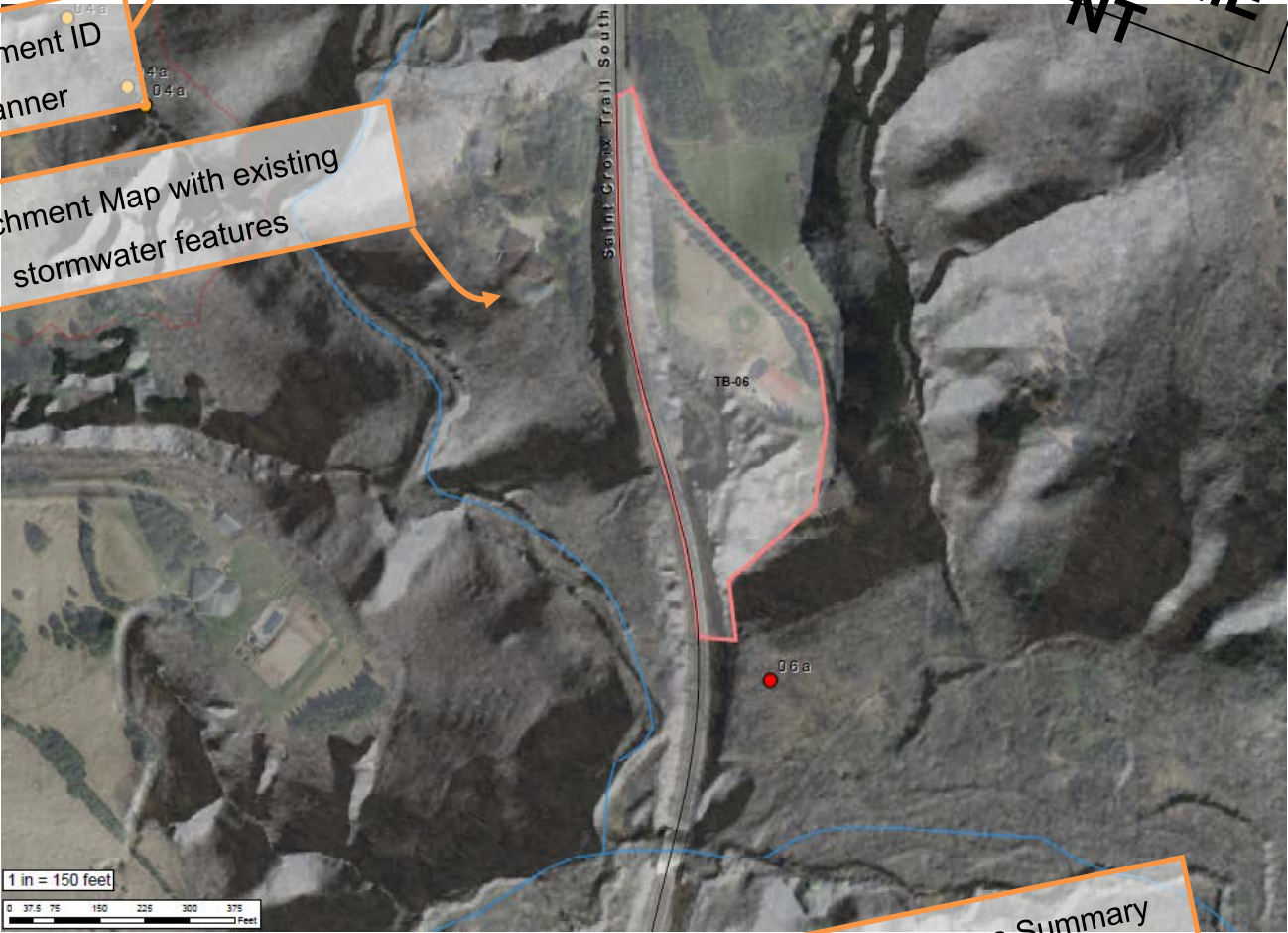

Existing Conditions Summary
*(includes existing BMPs and large wooded
depressions)*

CATCHMENT DESCRIPTION

Catchment TB-06 is along Stagecoach Trail. It's a small steep catchment that drains to a large flat above Trout Brook. There are multiple head cuts that exist along the road that flow into one large channel as it progresses south towards the creek. Much of the sand that deposits in the flat above the creek eventually gets washed into the creek, even though it appears there is ample room for settling to occur. The road will be at risk of undercutting in the future if something is not done about the erosion.

It appears many attempts at repairing this erosion have taken place, all of which just move the erosion further south along the roadway. The only true fix would be to install a full concrete curb, and collect it at the bottom of the hill, diverting it to a new basin downhill where the water can deposit sediment safely before entering the stream.

TB-06: BMP 6a – New Curb and Gabion Basin

Practice Ranking, Color Coded

Rank
3 of 12

Drainage Area – 3.70 acres

Location – Intersection of Trout Brook trailhead along Stagecoach, TB-06

Property Ownership – Public/Private, City of Afton/Washington County/ Afton State Park

BMP Name
and Site
Description

Description – Install 500LF of new concrete curb to divert flow to downstream gabion basin.

By installing 500LF of concrete curb, the vast majority of erosion can be stopped in this ravine. This new curb will divert flow to a single structure near the 796' contour in the roadway, and discharge into a shallow basin that is constructed behind a gabion wall 1 course high (2' of vertical storage). There will be roughly 150LF of gabion wall, which has about 3000sf of storage area. There is enough storage volume behind this wall to require cleanout every 25 years. A berm with an armored weir would also be possible here, but infiltration of underlying soils would be a practical consideration since an earthen berm does not weep like a gabion wall would. If installing in Afton State Park is not viable, there is the possibility to store all of this volume on the property north of the park, in the ravine itself where the flow path starts to widen. All overflows would still flow into the park property as it currently exists.

Practice Design Narrative

Proposed BMP Catchment Boundary and BMP Location

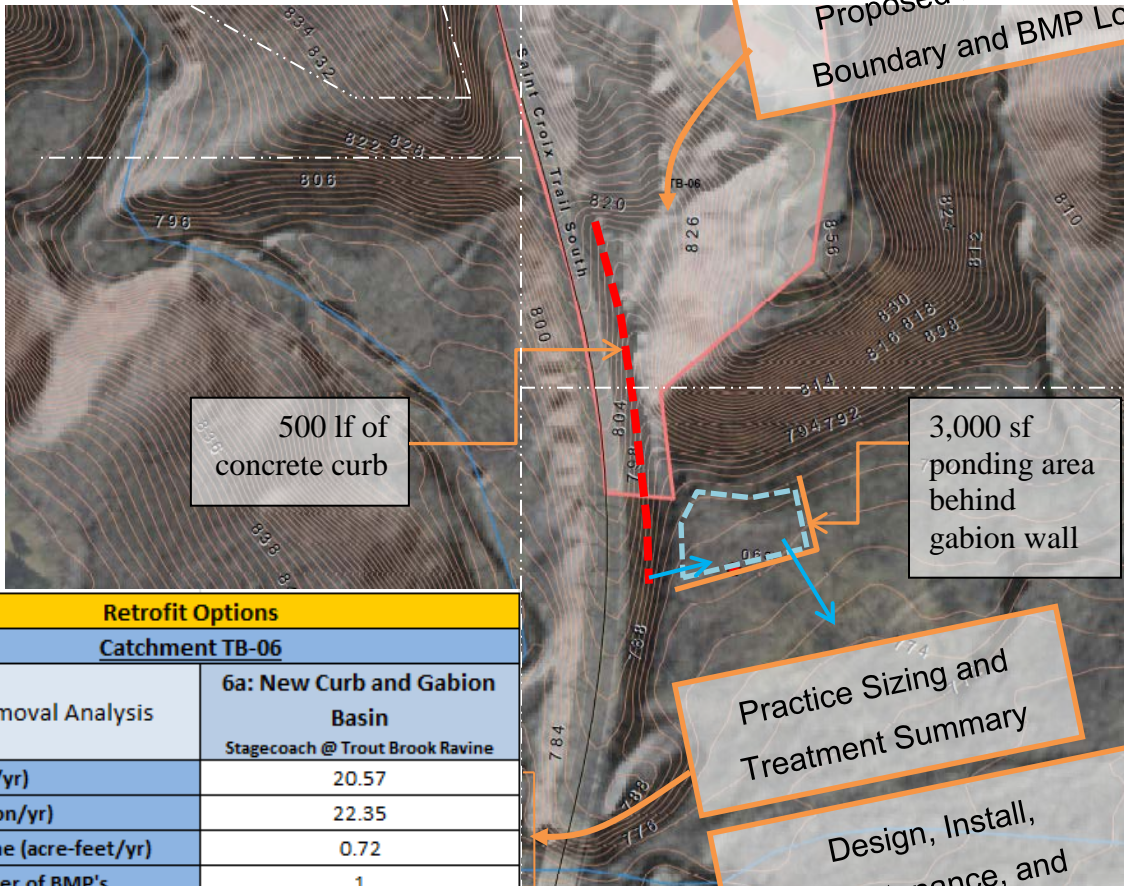

Retrofit Options		
Catchment TB-06		
Cost/Removal Analysis		6a: New Curb and Gabion Basin
		Stagecoach @ Trout Brook Ravine
Treatment	TP (lb/yr)	20.57
	TSS (ton/yr)	22.35
	Volume (acre-feet/yr)	0.72
	Number of BMP's	1
Cost	Materials/Labor/Design	\$53,480.55
	Promotion & Admin Costs	\$3,000
	Probable Project Cost	\$56,481
	Annual O&M	\$200
	30-yr Cost/lb-TP/yr	\$101
	30-yr Cost/ton-TSS/yr	\$93

Practice Sizing and Treatment Summary

Design, Install, Maintenance, and Promotion Costs (embedded in final ranked cost)

Proposed Cost per Lb of TP and TSS

Intentionally Blank

Appendix C:

Ranking Tables and Maps for all BMPs

Intentionally Blank

RANKING TABLE: All Proposed Practices



Ranked by Cost per LB of TP reduced per year (over 30 years).

RANKED BY

Project Rank	Catchment ID (TB-##)	Retrofit Type (refer to catchment profile pages for additional detail)	Locations Identified	TP Reduction (lb/yr)	TSS Reduction (ton/yr)	Volume Reduction (ac-ft/yr)	Total Project Cost	Estimated Annual O & M (2017 Dollars)	Estimated cost/lb-TP/year (30-year)	Estimated cost/ton-TSS/year (30-year)
1	TB-15	15a+b: Upper Ravine Stabilization	10	26.06	29.2	0.6	\$46,340	\$133	\$64.39	\$57.56
2	TB-01	1a: Head Cut Repairs and Rate Control	1	17.7	15	0.0	\$41,058	\$100	\$82.97	\$95.36
3	TB-06	6a: New Curb and Gabion Basin	1	20.57	22.35	0.72	\$56,481	\$200	\$101.25	\$93.19
4	TB-13	13a: Bank Stabilization and Headcut Repair	4	12.63	14.8	0.0	\$37,774	\$67	\$104.97	\$89.40
5	TB-14	14e: Gabion Sediment Basin	1	33.51	33.5	0.0	\$88,924	\$833	\$113.31	\$113.31
6	TB-14	14c + d: Thalweg and Pipe Corrections	10	7.01	7.0	0.0	\$32,250	\$75	\$164.05	\$164.05
7	TB-04	4a: Head Cut Repairs and Rate Control	3	8.37	5.1	0.8	\$52,381	\$333	\$248.43	\$409.32
8	TB-15	15c: Lower Ravine Thalweg Corrections	10	5.60	6.6	0.0	\$45,584	\$133	\$295.08	\$250.37
9	TB-14	14b: Pond IESF Retrofit	1	1.60	0.59	0.17	\$18,271	\$200	\$505.65	\$1,371.24
10	TB-14	14a: Pond IESF Retrofit	1	1.25	0.48	0.07	\$15,566	\$167	\$548.43	\$1,422.27
11	TB-03	3a: Head Cut Repairs and Rate Control	1	0.92	0.9	0.0	\$14,751	\$100	\$643.15	\$643.15
12	TB-10	10a: Headcut Repair	1	0.53	0.6	0.0	\$12,944	\$75	\$955.60	\$816.88

Catchments Studied – Catchments studied in this report. All ravines that showed potential erosion from the Stream Power Index were field verified for retrofit/repair potential.

Rank by Total Phosphorus Reduction

-  Catchments Modelled for Retrofit
-  High SPI Rank, but Field Verified as Stable – Not Modelled for Retrofit
-  Trout Brook Catchment Boundary

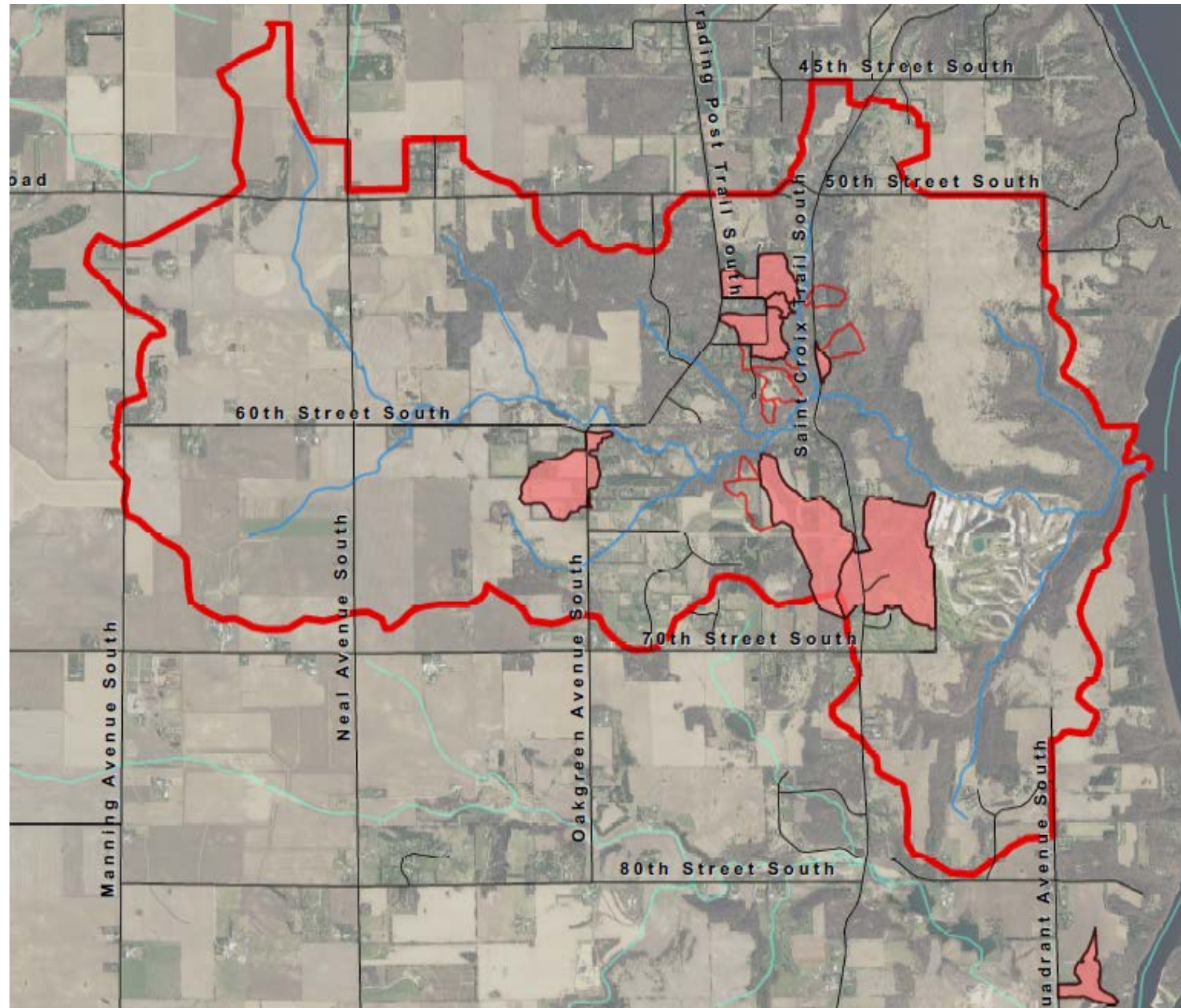

Prioritized Rankings by Catchment - rank of stormwater catchments studied to in this report
(Ranked by TP load reduction if all practices were installed per ravine catchment)

Rank by Total Phosphorus Reduction

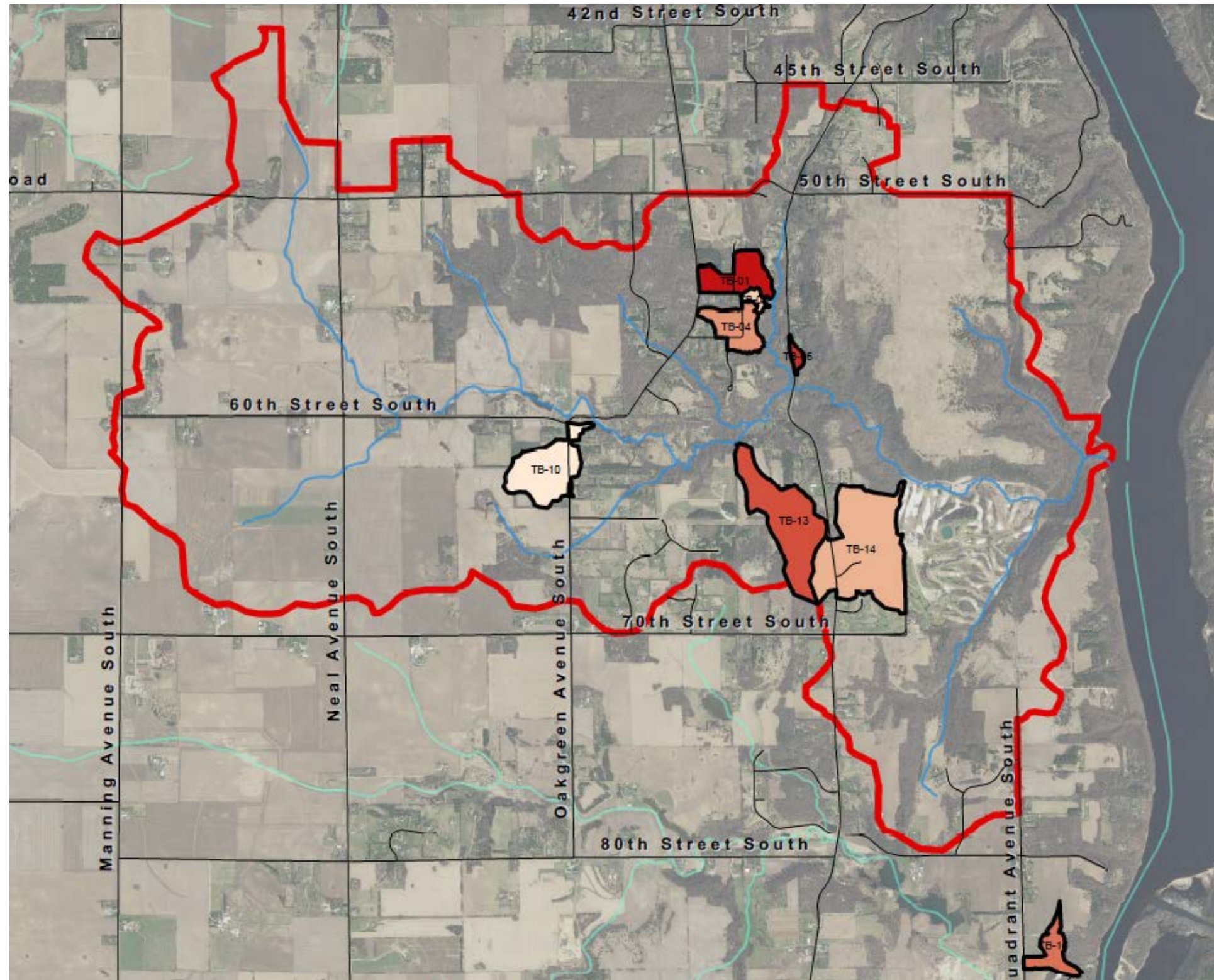
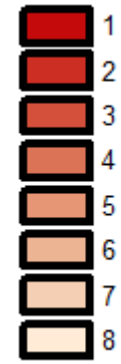

Ranking map of locations of standalone BMP projects referred to in this report. This map only includes BMP locations (ranking table on preceding page). The 'Catchment Profiles' section provides additional detail on these projects. See Appendix for additional ranking of all identified practices.

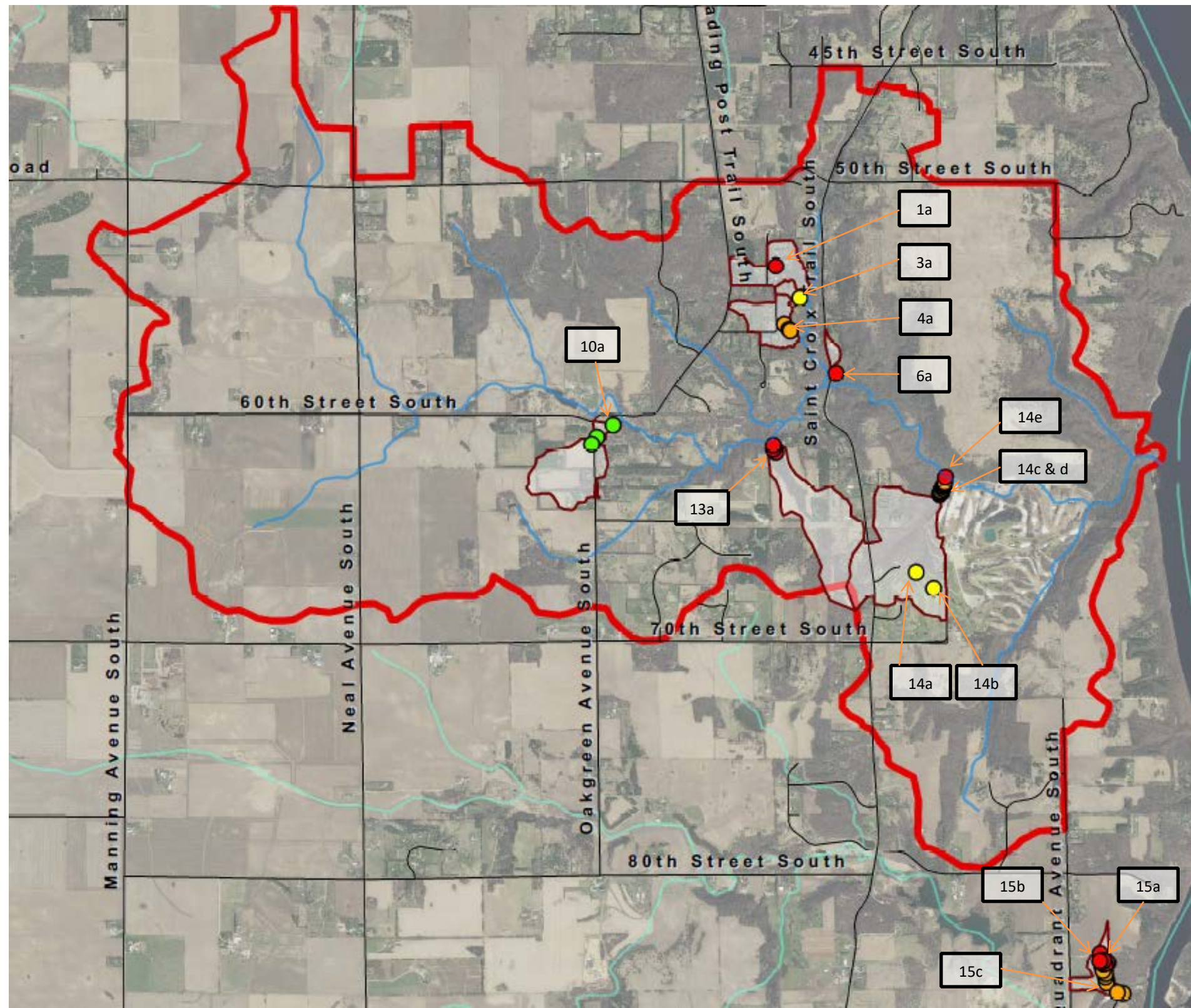
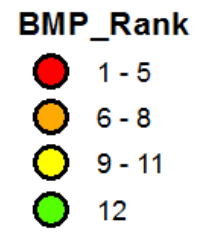

Catchment TB-01 (Catchment)



Catchment TB-01 (BMP Site)

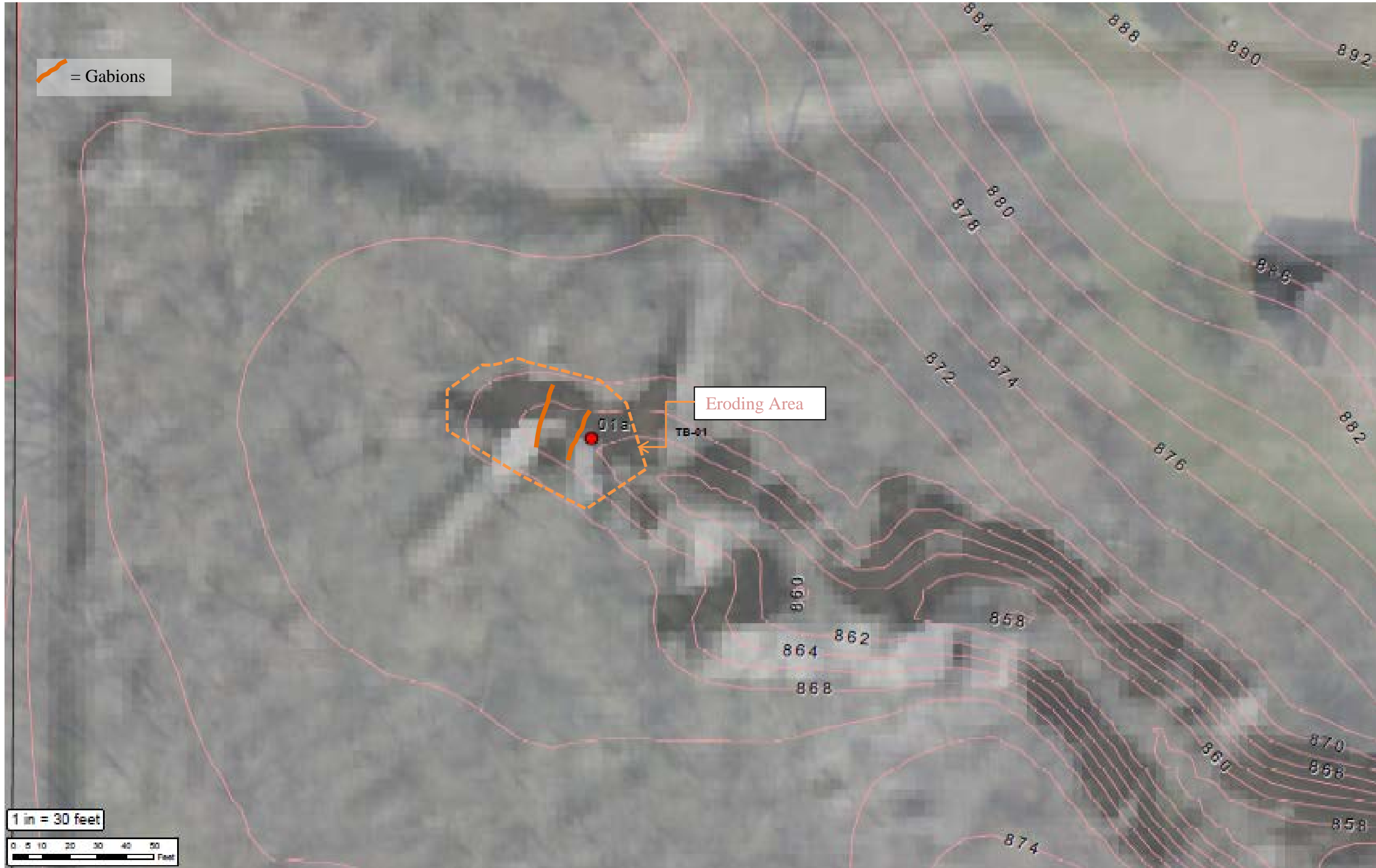

Catchment TB-03 (Catchment)



Catchment TB-03 (BMP Site)



Catchment TB-04 (Catchment)



Catchment TB-04 (BMP Site)

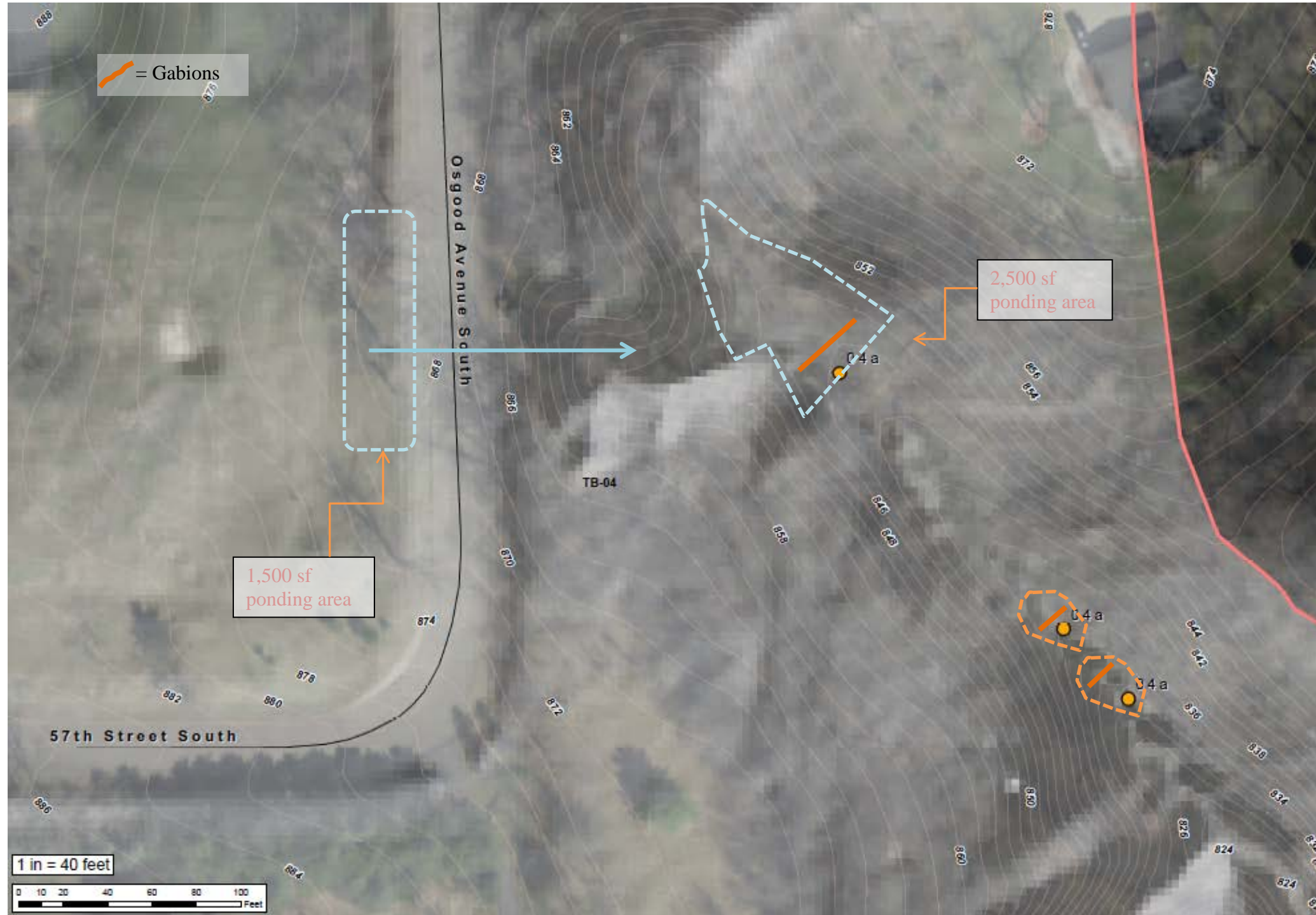

Catchment TB-06 (Catchment)



Catchment TB-06 (BMP Site)

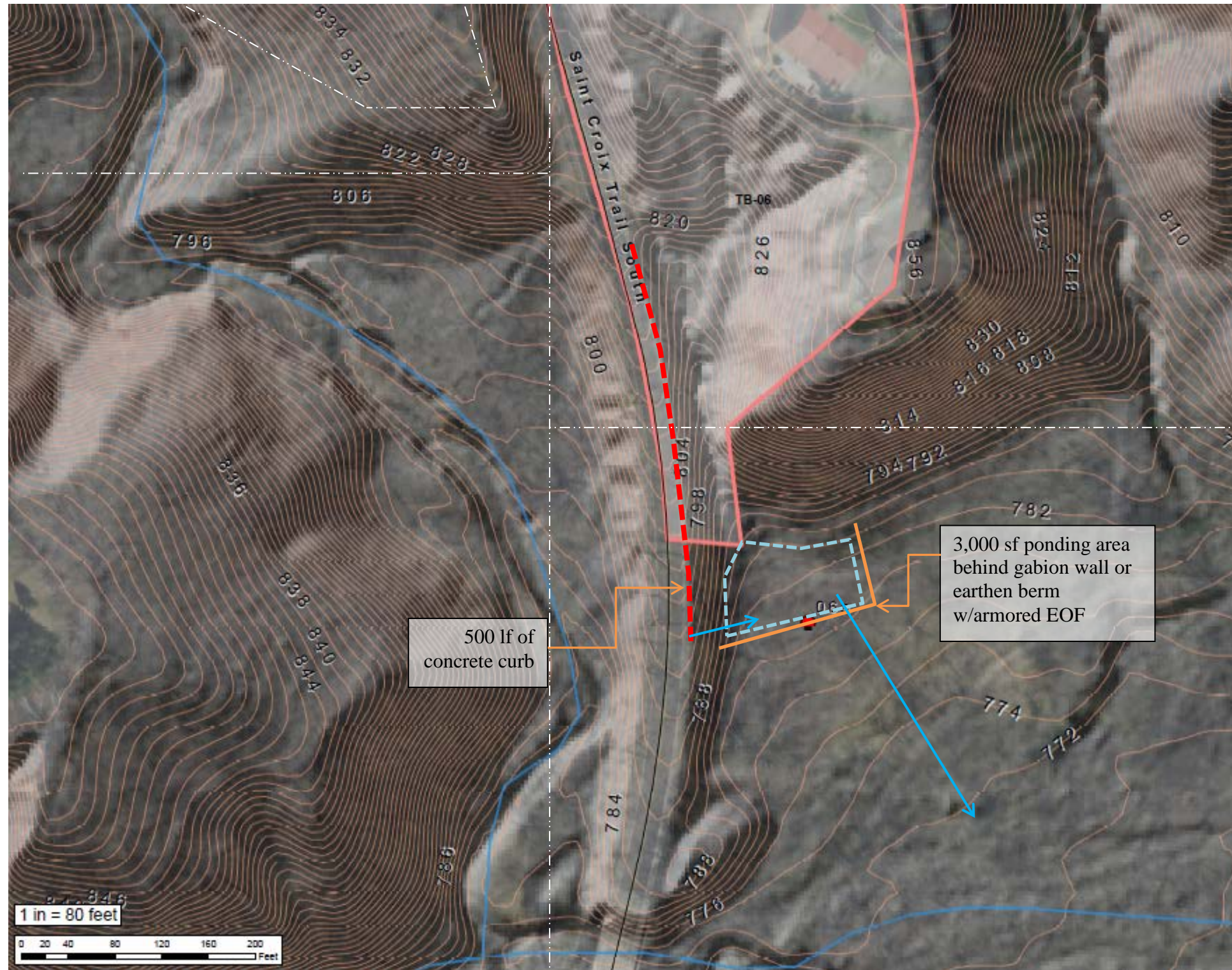

Catchment TB-10 (Catchment)



Catchment TB-10 (BMP Site)



Catchment TB-13 (Catchment)



Catchment TB-13 (BMP Site)

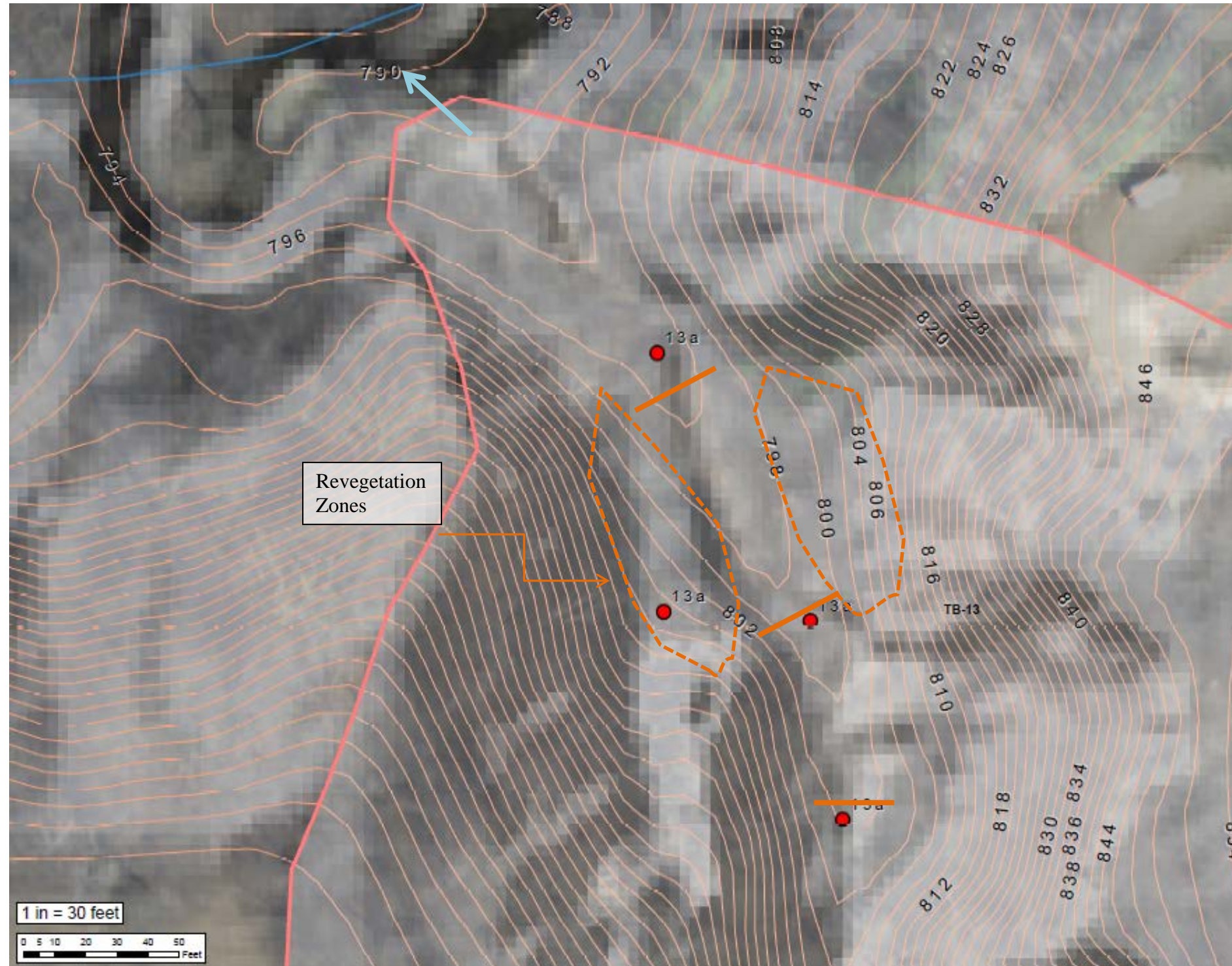

Catchment TB-14 (Catchment)



Catchment TB-14a + 14b (BMP Site)



Catchment TB-14a (BMP Site)



Catchment TB-14b (BMP Site)



Catchment TB-14c + 14d (BMP Site)

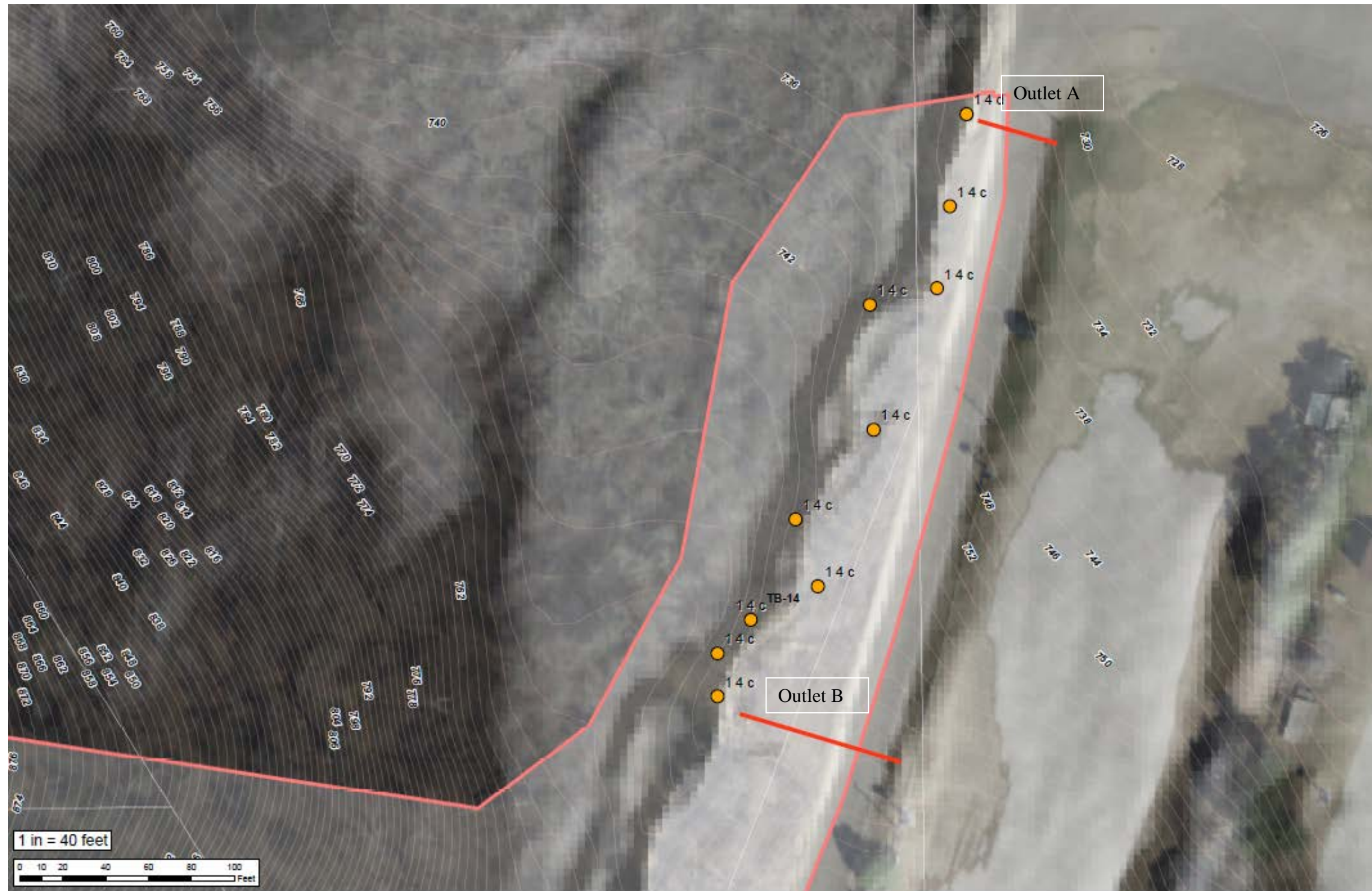

Catchment TB-14e (BMP Site)



Catchment TB-15 (Catchment)



Catchment TB-15a + 15b (BMP Site)

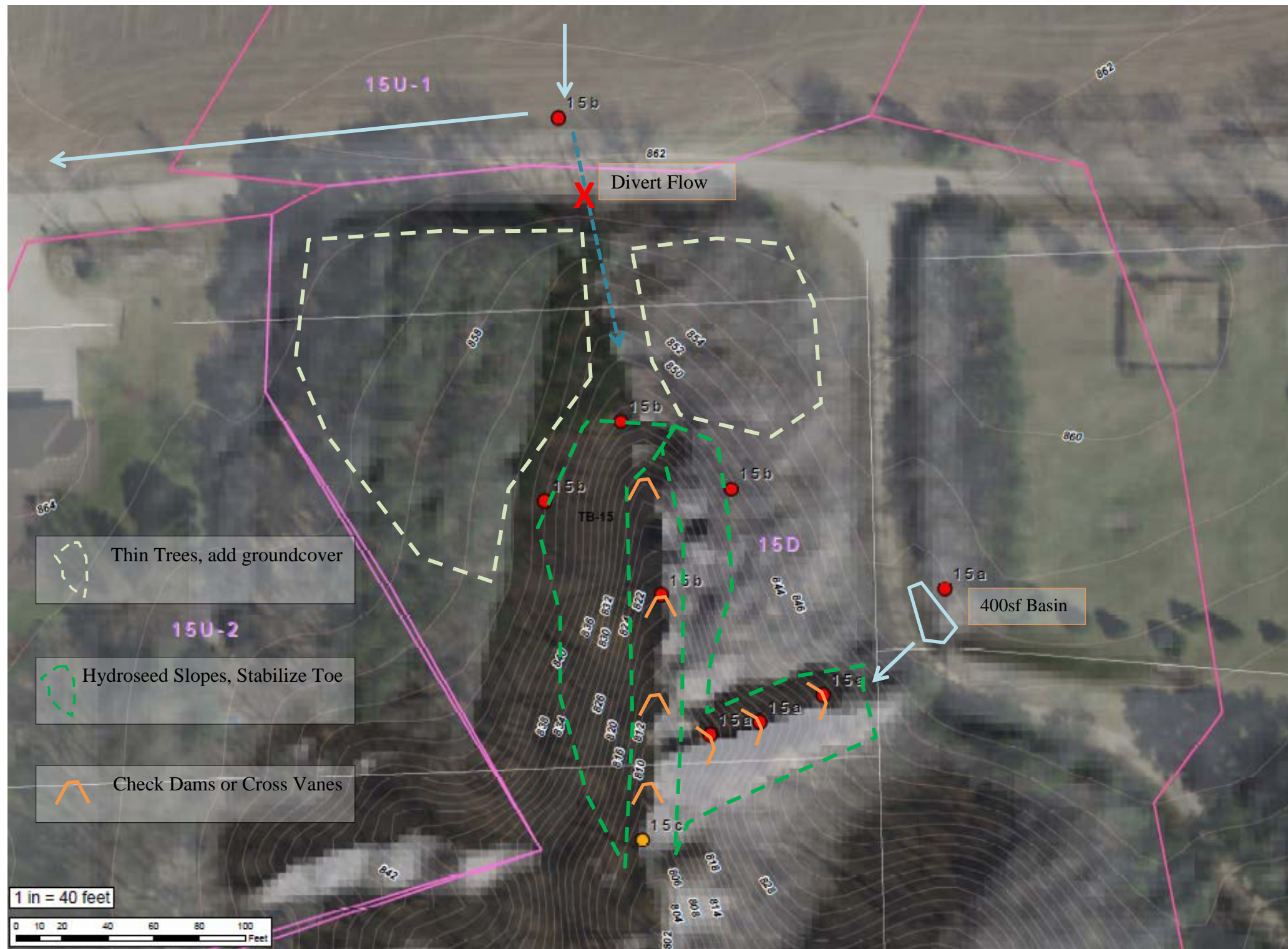

Catchment TB-15c (BMP Site)

